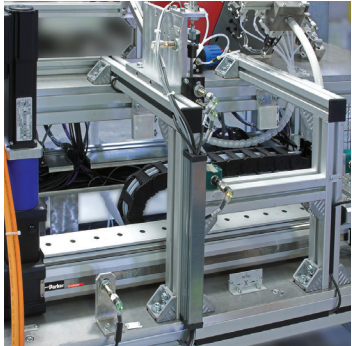




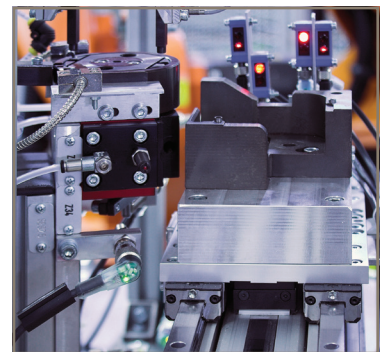
aerospace  
climate control  
electromechanical  
filtration  
fluid & gas handling  
hydraulics  
**pneumatics**  
process control  
sealing & shielding



# Handling Products

Comprising an innovative range of  
Grippers, Rotary Tables and Slide Tables

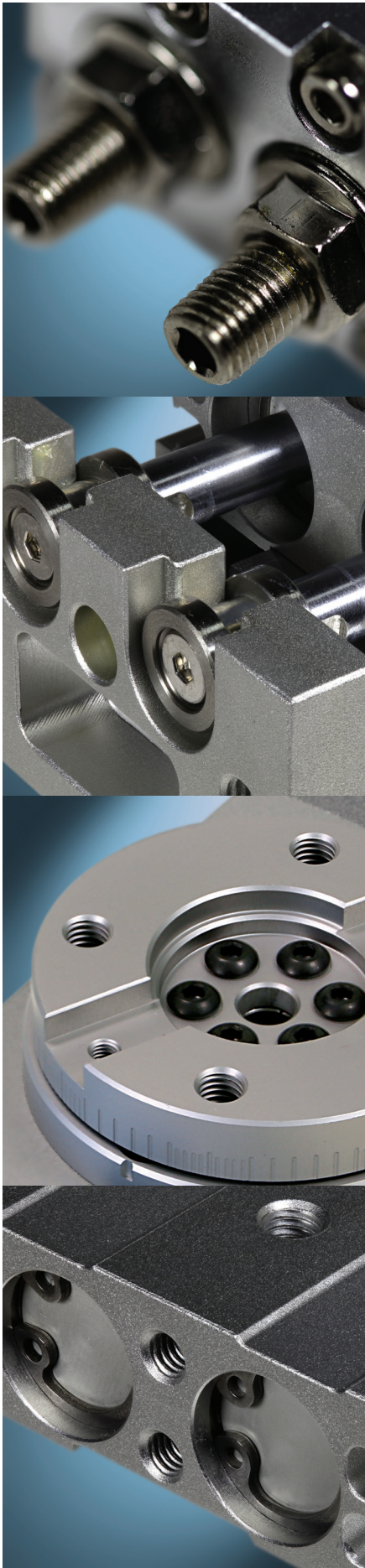
PDE2669TCUK April 2016



ENGINEERING YOUR SUCCESS.

# Handling Products

A pneumatic range of Grippers, Rotary Actuators and Slide Tables.




Parker is about motion control engineering, manufacturing, application expertise and unparalleled customer service.


Parker products are everywhere — from laboratories, cleanrooms and factory floors, to mines, foundries and satellites in space — our products are used anywhere machines, processes and people depend on reliable high-performance motion control.

Today's industrial handling applications demand the best in quality and productivity. Likewise, high-technology applications demand performance in quality throughput and precision.


| <b>Contents</b>                                 | <b>page</b> |
|---|-------------|
| Features .....                                  | 4           |
| P5G Series Grippers .....                       | 5           |
| Angular Grippers - P5GA Series .....            | 10          |
| Parallel Grippers - P5GB Series .....           | 18          |
| Parallel Precision Grippers - P5GD Series ..... | 26          |
| 180° Angular Grippers - P5GL Series .....       | 37          |
| Rotary Tables - P5RS Series .....               | 47          |
| Slide Tables - P5SS Series .....                | 63          |



**Important**  
 Before attempting any external or internal work on the cylinder or any connected components, make sure the cylinder is vented and disconnect the air supply in order to ensure isolation of the air supply.



**Note**  
 All technical data in this catalogue are typical data only.  
 Air quality is essential for maximum cylinder service life (see ISO 8573).

 **WARNING**

**FAILURE OR IMPROPER SELECTION OR IMPROPER USE OF THE PRODUCTS AND/OR SYSTEMS DESCRIBED HEREIN OR RELATED ITEMS CAN CAUSE DEATH, PERSONAL INJURY AND PROPERTY DAMAGE.**  
 This document and other information from Parker Hannifin Corporation, its subsidiaries and authorized distributors provide product and/or system options for further investigation by users having technical expertise. It is important that you analyze all aspects of your application and review the information concerning the product or system in the current product catalog. Due to the variety of operating conditions and applications for these products or systems, the user, through its own analysis and testing, is solely responsible for making the final selection of the products and systems and assuring that all performance, safety and warning requirements of the application are met. The products described herein, including without limitation, product features, specifications, designs, availability and pricing, are subject to change by Parker Hannifin Corporation and its subsidiaries at any time without notice.

**SALE CONDITIONS**

The items described in this document are available for sale by Parker Hannifin Corporation, its subsidiaries or its authorized distributors. Any sale contract entered into by Parker will be governed by the provisions stated in Parker's standard terms and conditions of sale (copy available upon request).

# Complete Automation Solution

Parker Pneumatic Division is a single source supplier for all your automation needs. Selecting the right product for your application is easy with Parker Hannifin's extensive offering of pneumatic grippers, slide tables and rotary tables. Integration into your automation system is fast and simple using a variety of online e-configurators and CAD drawings.

## Holding

### Angular Grippers P5GA Series



- Bores 12, 16, 20, 25 and 32mm
  - Working angle of  $-10^{\circ}$  to  $+30^{\circ}$
  - Closed force of 13N to 203N
- See page - 5

### Parallel Grippers P5GB Series



- Bores 12, 16, 20, 25 and 32mm
  - Working stroke of 6mm to 16mm
  - Closed force of 10N to 170N
- See page - 18

### Parallel Grippers P5GD Precision Series



- Bores 10, 16, 20 and 25mm
  - Working stroke of 4mm to 14mm
  - Closed force of 22N to 130N
- See page - 26

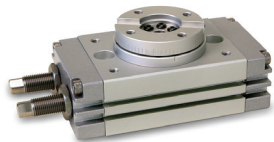
### 180° Angular Grippers P5GL Series



- Bores 10, 16, 20 and 25mm
  - Working angle of  $-3^{\circ}$  to  $180^{\circ}$
  - Closed force of 11N to 152N
- See page - 37

## Rotating

### Rotary Actuators P5RS Series



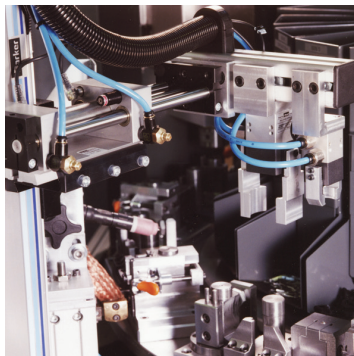
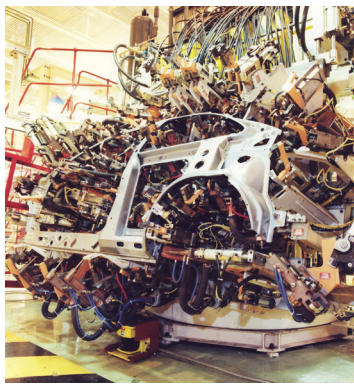
- Bores 16, 20, 25 and 32mm
  - Rotation angle of 0 to  $190^{\circ}$
  - Working torque from 1.21 to 9.86Nm
- See page - 47

## Moving

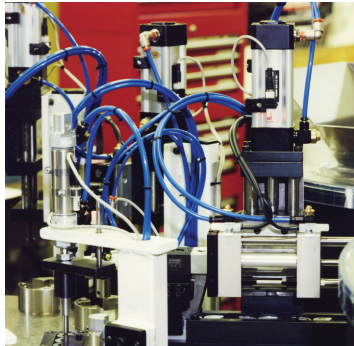
### Slides P5SS Series



- Bores 6, 8, 12, 16, 20 and 25mm
  - Strokes 10mm to 150mm
- See page - 63



aerospace  
climate control  
electromechanical  
filtration  
fluid & gas handling  
hydraulics  
**pneumatics**  
process control  
sealing & shielding



# Grippers P5G Series

Sizes 10, 12, 16, 20, 25 and 32 mm



ENGINEERING YOUR SUCCESS.

| <b>Contents</b>                                 | <b>page</b> |
|---|-------------|
| Features .....                                  | 7           |
| Choice of Grippers .....                        | 8           |
| Angular Grippers - P5GA Series .....            | 10          |
| Parallel Grippers - P5GB Series .....           | 18          |
| Parallel Precision Grippers - P5GD Series ..... | 26          |
| 180° Angular Grippers - P5GL Series .....       | 37          |
| Installation and Maintenance .....              | 44          |



**Important**

Before attempting any external or internal work on the cylinder or any connected components, make sure the cylinder is vented and disconnect the air supply in order to ensure isolation of the air supply.



**Note**

All technical data in this catalogue are typical data only.  
 Air quality is essential for maximum cylinder service life (see ISO 8573).



**WARNING**

**FAILURE OR IMPROPER SELECTION OR IMPROPER USE OF THE PRODUCTS AND/OR SYSTEMS DESCRIBED HEREIN OR RELATED ITEMS CAN CAUSE DEATH, PERSONAL INJURY AND PROPERTY DAMAGE.**

This document and other information from Parker Hannifin Corporation, its subsidiaries and authorized distributors provide product and/or system options for further investigation by users having technical expertise. It is important that you analyze all aspects of your application and review the information concerning the product or system in the current product catalog. Due to the variety of operating conditions and applications for these products or systems, the user, through its own analysis and testing, is solely responsible for making the final selection of the products and systems and assuring that all performance, safety and warning requirements of the application are met. The products described herein, including without limitation, product features, specifications, designs, availability and pricing, are subject to change by Parker Hannifin Corporation and its subsidiaries at any time without notice.

**SALE CONDITIONS**

The items described in this document are available for sale by Parker Hannifin Corporation, its subsidiaries or its authorized distributors. Any sale contract entered into by Parker will be governed by the provisions stated in Parker's standard terms and conditions of sale (copy available upon request).

**General technical data**



| Series                                     | P5GA                                |      |      |      |      | P5GB                                |      |      |      |      | P5GD                                |          |      |      | P5GL                                |      |      |      |
|--|-------------------------------------|------|------|------|------|-------------------------------------|------|------|------|------|-------------------------------------|----------|------|------|-------------------------------------|------|------|------|
|  | 12                                  | 16   | 20   | 25   | 32   | 12                                  | 16   | 20   | 25   | 32   | 10                                  | 16       | 20   | 25   | 10                                  | 16   | 20   | 25   |
| Size                                       | 12                                  | 16   | 20   | 25   | 32   | 12                                  | 16   | 20   | 25   | 32   | 10                                  | 16       | 20   | 25   | 10                                  | 16   | 20   | 25   |
| Total stroke (mm)                          | -                                   |      |      |      |      | 6                                   | 9    | 12   | 14   | 16   | 4                                   | 6        | 10   | 14   | -                                   |      |      |      |
| Total operating angle (°)                  | -10° to +30°                        |      |      |      |      | -                                   |      |      |      |      | -                                   |          |      |      | -3° to +180°                        |      |      |      |
| Total Force* (N) - Closed side             | 13                                  | 30   | 57   | 113  | 203  | 10                                  | 26   | 70   | 120  | 170  | 22                                  | 68       | 94   | 130  | 11                                  | 36   | 73   | 152  |
| Total Force* (N) - Open side               | 17                                  | 40   | 77   | 147  | 270  | 16                                  | 48   | 94   | 140  | 200  | 34                                  | 90       | 132  | 208  | -                                   |      |      |      |
| Total Torque* (Nm) - Closed side           | 0.40                                | 0.90 | 1.70 | 3.40 | 6.10 | -                                   |      |      |      |      | -                                   |          |      |      | 0.32                                | 1.08 | 2.20 | 4.56 |
| Total Torque* (Nm) - Open side             | 0.50                                | 1.20 | 2.30 | 4.40 | 8.10 | -                                   |      |      |      |      | -                                   |          |      |      | -                                   |      |      |      |
| Ø Piston bore (mm)                         | 12                                  | 16   | 20   | 25   | 32   | 12                                  | 16   | 20   | 25   | 32   | 10                                  | 16       | 20   | 25   | 10                                  | 16   | 20   | 25   |
| Ø Air port size (mm)                       | M3                                  | M5   |      |      |      | M3                                  | M5   |      |      |      | M3                                  | M5       |      |      | M5                                  |      |      |      |
| Air consumption (cm <sup>3</sup> cycle) ** | 0.7                                 | 3    | 6    | 11   | 18   | 0.7                                 | 3    | 7    | 14   | 21   | 0.5                                 | 2        | 6    | 14   | 2                                   | 7    | 14   | 28   |
| Repeatability (mm)                         | -                                   |      |      |      |      | ± 0.04                              |      |      |      |      | ± 0.01                              |          |      |      | -                                   |      |      |      |
| Repeatability (°)                          | ± 0.04                              |      |      |      |      | -                                   |      |      |      |      | -                                   |          |      |      | ± 0.2                               |      |      |      |
| Max. work frequency (Hz)                   | 3                                   |      |      |      |      | 3                                   |      |      |      |      | 3                                   |          |      |      | 1                                   |      |      |      |
| Min. closing time (s)                      | 0.01                                | 0.01 | 0.02 | 0.02 | 0.03 | 0.015                               | 0.02 | 0.05 | 0.07 | 0.09 | 0.015                               | 0.02     | 0.05 | 0.07 | 0.1                                 | 0.1  | 0.15 | 0.15 |
| Weight (g)                                 | 53                                  | 103  | 193  | 327  | 525  | 66                                  | 144  | 255  | 479  | 719  | 55                                  | 125      | 250  | 450  | 80                                  | 150  | 320  | 600  |
| Max. jaw length (mm)                       | 30                                  | 40   | 60   | 70   | 85   | 30                                  | 40   | 60   | 70   | 85   | 50                                  | 55       | 80   | 100  | 60                                  | 70   | 80   | 90   |
| Max. temperature (°C)                      | -5° to +60°                         |      |      |      |      | -5° to +60°                         |      |      |      |      | -10° to +60°                        |          |      |      | -10° to +60°                        |      |      |      |
| Air pressure (bar)                         | 1.5 to 7                            |      |      |      |      | 1.5 to 7                            |      |      |      |      | 2 to 7                              | 1.5 to 7 |      |      | 1 to 6                              |      |      |      |
| Operation                                  | Dry air, lubricated or unlubricated |      |      |      |      | Dry air, lubricated or unlubricated |      |      |      |      | Dry air, lubricated or unlubricated |          |      |      | Dry air, lubricated or unlubricated |      |      |      |

\* At 5 bar at closing, force depends on position of the holding point, values are for 30mm, 20mm for P5GD

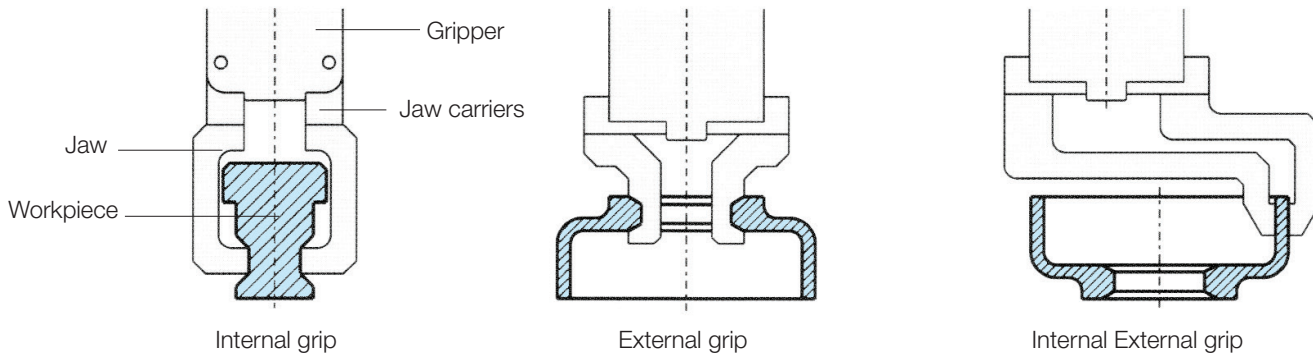
\*\* Cycle = opening + closing (without jaws)

**Operating and environmental data**

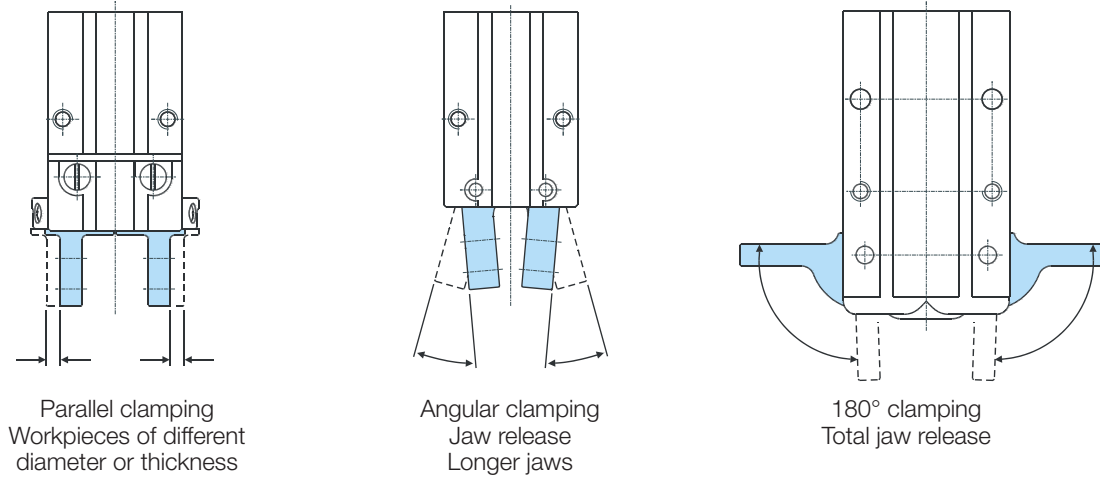
|                      |  |
|----------------------|--|
| Operating medium     | For best possible service life and trouble-free operation dry, filtered compressed air to ISO 8573-1:2010 quality class 3.4.3 should be used. This specifies a dew point of +3C for indoor operation (a lower dew point should be selected for outdoor operation) and is in line with the air quality from most standard compressors with a standard filter. |
| Operating pressure   | See above  |
| Ambient temperature  | See above  |
| Pre-lubricated       | Further lubrication is normally not necessary. If additional lubrication is introduced it must be continued.   |
| Corrosion resistance | Resistance to corrosion and chemicals.   |

**Choice of gripper**

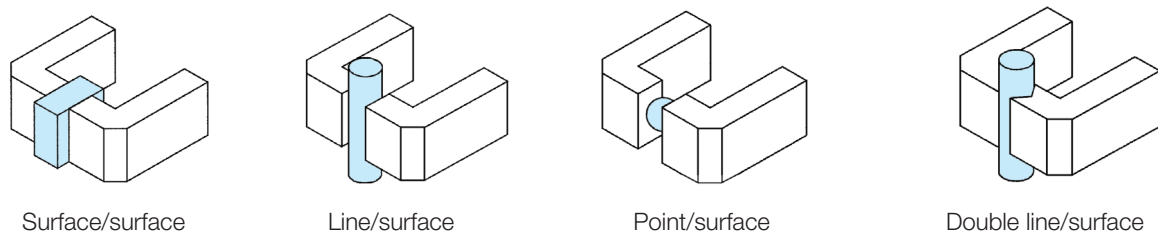
**Types of grip**



**Types of clamping**



**Contact between workpiece/jaw**



**Main points to note in selecting grippers :**

- The weight of the workpiece to be moved
- Geometry and volume of the workpiece
- The type of gripper (parallel or angular)
- Dynamic movement of gripper and workpiece combination
- Environment (shocks, additional external forces...)
- Coefficient of friction between workpiece and jaws (see chart below)

| Workpiece material | Jaw material | Coefficient of friction $\mu$ |
|--------------------|--------------|-------------------------------|
| Steel              | Steel        | 0,25                          |
| Steel              | Aluminium    | 0,35                          |
| Steel              | Plastic      | 0,50                          |
| Aluminium          | Aluminium    | 0,49                          |
| Aluminium          | Plastic      | 0,70                          |
| Plastic            | Plastic      | 1                             |

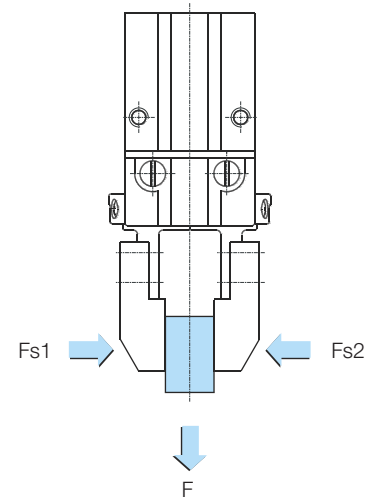
**Formula calculation for clamping force**

For internal or external clamping

**Fs1 = Fs2**

$$F_s = F_{s1} + F_{s2} = \frac{F}{\mu} \times S_o$$

- Fs : Clamping force (N)
- F : Force acting on jaws (N)  
 (When static F corresponds to the weight of the workpiece in N)
- μ : Coefficient of friction between the workpiece and jaws (μ < 1)
- So : Safety factor (between 2 and 4, refer to chart below)



| Safety factor So | Type of use   |
|------------------|---|
| 2                | Normal use  |
| 3                | Movement in several directions (slow acceleration or decelerations) |
| 4                | Shocks, fast accelerations or decelerations                         |

### P5GA - Angular double acting, square jaw carriers

The P5GA is a compact angular gripper with a closed angle of  $-10^\circ$  and an open angle of  $+30^\circ$ .

With double acting mechanism the gripper is suitable for internal or external gripping applications.

For flexible installation mounting is available on three sides and the anodised body has recessed sensor grooves.

- Bore sizes  $\varnothing$  12, 16, 20, 25 and 32 mm
- Double acting
- Anodised corrosion protection
- Magnetic piston as standard
- Optional sensors

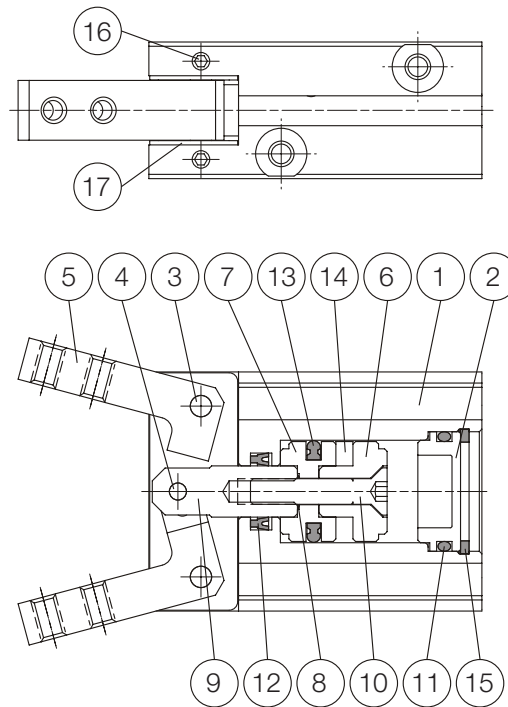


### General technical data

| Size                                       | 12                                  | 16   | 20   | 25   | 32   |
|--|-------------------------------------|------|------|------|------|
| Total operating angle (°)                  | -10° to +30°                        |      |      |      |      |
| Total Force* (N) - Closed side             | 13                                  | 30   | 57   | 113  | 203  |
| Total Force* (N) - Open side               | 17                                  | 40   | 77   | 147  | 270  |
| Total Torque* (Nm) - Closed side           | 0.40                                | 0.90 | 1.70 | 3.40 | 6.10 |
| Total Torque* (Nm) - Open side             | 0.50                                | 1.20 | 2.30 | 4.40 | 8.10 |
| $\varnothing$ Piston bore (mm)             | 12                                  | 16   | 20   | 25   | 32   |
| $\varnothing$ Air port size (mm)           | M3                                  | M5   |      |      |      |
| Air consumption (cm <sup>3</sup> cycle) ** | 0.7                                 | 3    | 6    | 11   | 18   |
| Repeatability (°)                          | ± 0.04                              |      |      |      |      |
| Max. work frequency (Hz)                   | 3                                   |      |      |      |      |
| Min. closing time (s)                      | 0.01                                | 0.01 | 0.02 | 0.02 | 0.03 |
| Weight (g)                                 | 53                                  | 103  | 193  | 327  | 525  |
| Max. jaw length (mm)                       | 30                                  | 40   | 60   | 70   | 85   |
| Max. temperature (°C)                      | -5° to +60°                         |      |      |      |      |
| Air pressure (bar)                         | 1.5 to 7                            |      |      |      |      |
| Operation                                  | Dry air, lubricated or unlubricated |      |      |      |      |

\* At 5 bar, L=30mm.

\*\* Cycle = opening + closing (without jaws)



| Pos | Part              | Specification       |
|-----|-------------------|---------------------|
| 1   | Body              | Aluminium alloy     |
| 2   | Sealing cap       | Aluminium alloy     |
| 3   | Jaw spindle       | Medium carbon steel |
| 4   | Retaining pin     | Bearing steel       |
| 5   | Jaw carrier       | Medium carbon steel |
| 6   | Lower piston half | Aluminium alloy     |
| 7   | Upper piston half | Aluminium alloy     |
| 8   | Gasket            | NBR                 |
| 9   | Piston rod        | Stainless steel     |

| Pos | Part                   | Specification     |
|-----|------------------------|-------------------|
| 10  | Piston retaining screw | Stainless steel   |
| 11  | O ring                 | NBR               |
| 12  | U cup                  | NBR               |
| 13  | Piston seal            | NBR               |
| 14  | Magnet                 | Magnetic material |
| 15  | Circlip                | Spring steel      |
| 16  | Set screw              | SCM               |
| 17  | Guide plate            | Stainless steel   |
|     | Note on materials      | RoHS Compliant    |

**How to select the correct model (or required clamp force) according to the weight of workpiece.**

The friction coefficient of the workpiece will be influenced by the shape and shifting condition but in connection with the weight of workpiece, the safety factor of clamping force is as shown below. Please select your model according to the result of below calculation.

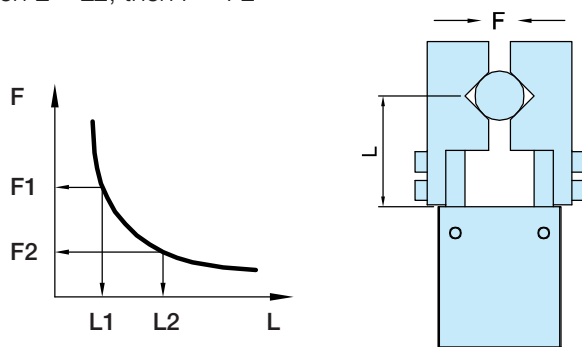
- Clamp force only                      W: (F×N) = 1:5
- Shifting under normal condition    W: (F×N) = 1:10
- Shifting under acceleration        W: (F×N) = 1:20

W = Weight of workpiece  
 F : Clamp force per jaw  
 (Please refer to clamp force performance chart)  
 N : Number of finger blanks

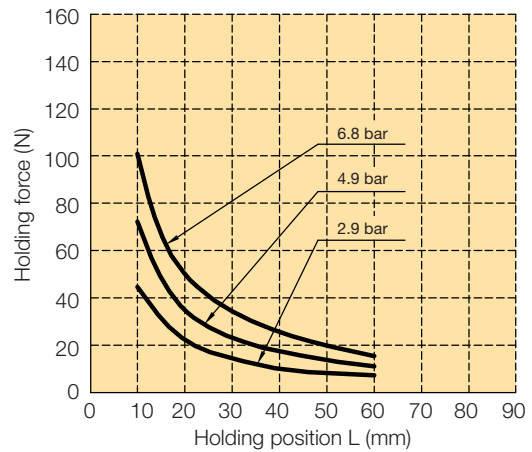
To obtain gripping power from performance data, if the distance to the workpiece's center of gravity is L when manufacturing the small jaw, gripping power F is expressed as follows

When L = L1, then F = F1

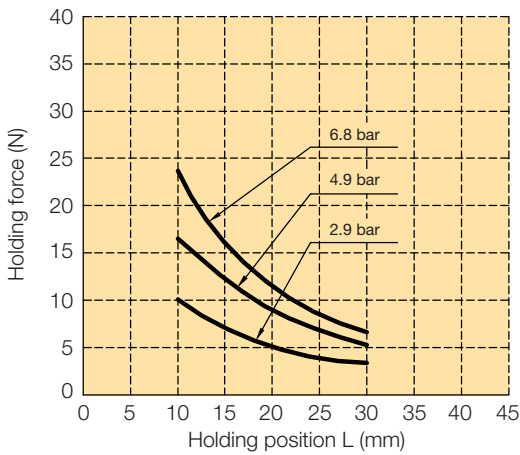
When L = L2, then F = F2



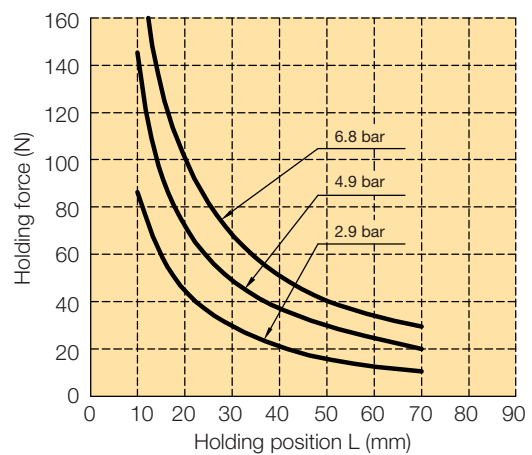
**P5GA-020MSG030B**



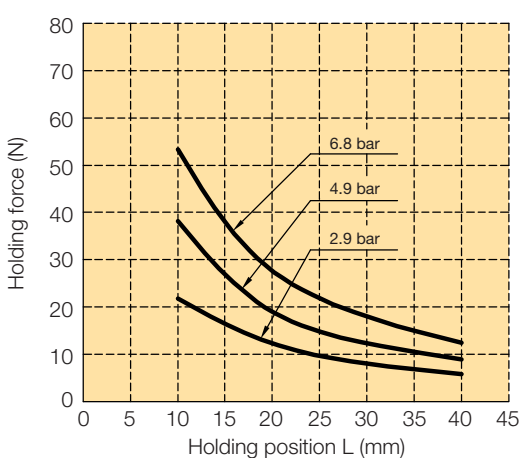
**P5GA-012MSG030B**



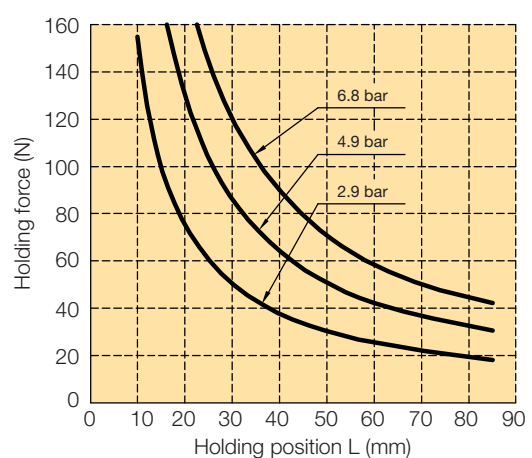
**P5GA-025MSG030B**



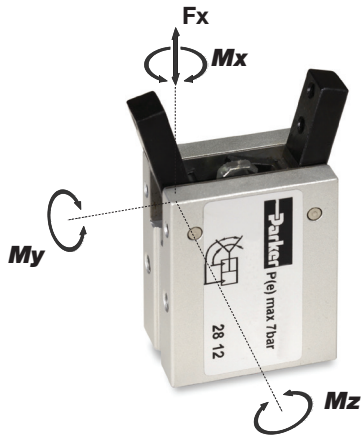
**P5GA-016MSG030B**



**P5GA-032MSG030B**



**P5GA - Permissible force and torques on each jaw carrier**



**Static**

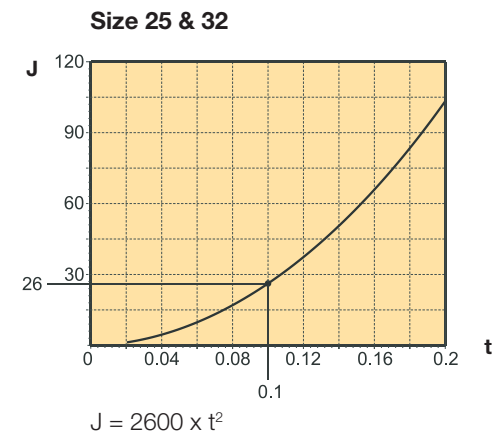
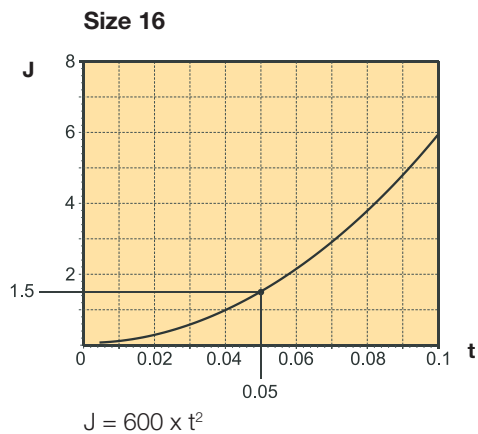
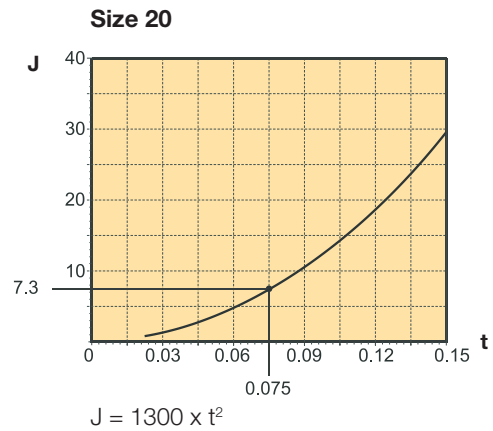
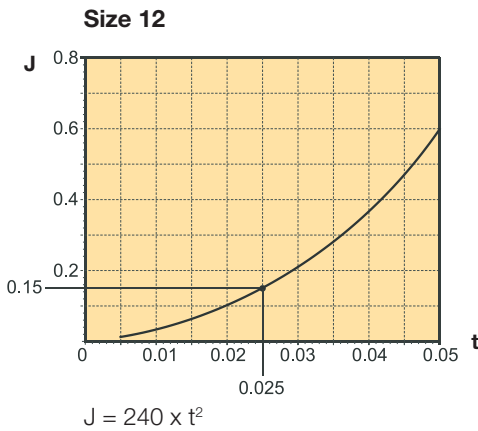
| Size | 12     | 16      | 20      | 25      | 32      |
|------|--------|---------|---------|---------|---------|
| Fx   | 40N    | 60N     | 100N    | 100N    | 100N    |
| Mx   | 0,5Nm  | 0,9 Nm  | 2,2 Nm  | 2,2 Nm  | 2,2 Nm  |
| My   | 0,5Nm  | 0,9 Nm  | 2,2 Nm  | 2,2 Nm  | 2,2 Nm  |
| Mz   | 0,20Nm | 0,45 Nm | 0,85 Nm | 1,70 Nm | 2,05 Nm |

Mz at 5 bar.

Recommendation is to use a flow control to limit the speed for opening to reduce impact at the end of the stroke.

**Dynamic**

**Inertia of one of the 2 jaws (kgcm<sup>2</sup>) closing or opening time (t) in seconds :**



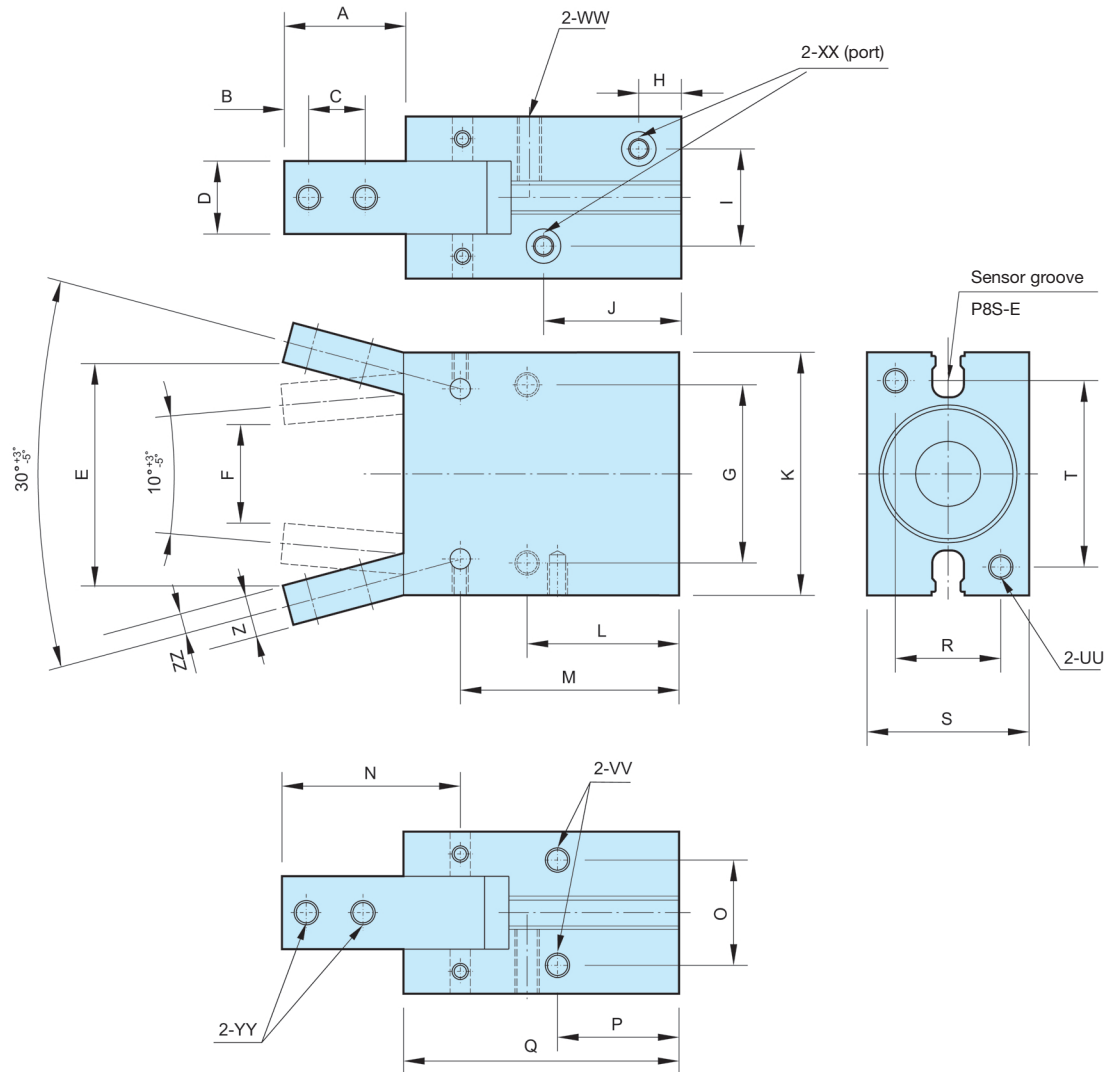
For a 0,15 kgcm<sup>2</sup> inertia one of the 2 jaws, the closing or opening time of the gripper is 0,025s for a **size 12**.

These indications must not be exceeded if :

- any extra forces are exerted on the workpiece or on the jaws, in addition to the force or the clamping torque.
- handling forces (acceleration, shocks, ...) must also be added.

These values are cumulative if the forces act in different directions at the same time.

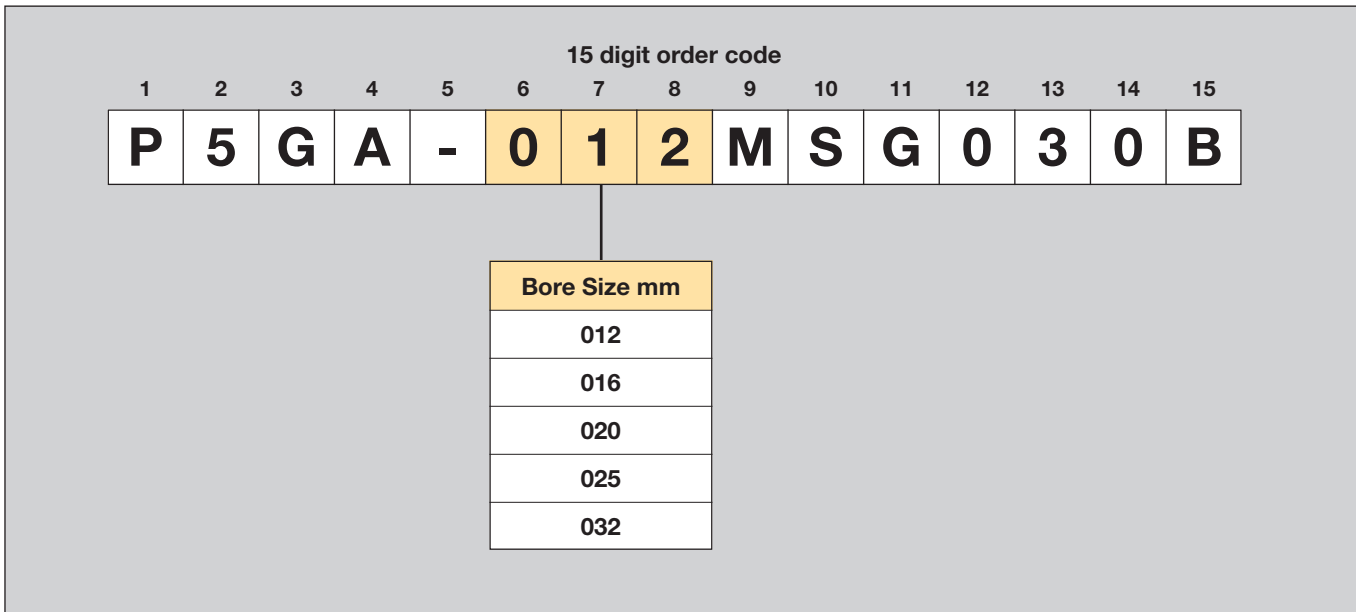
**Dimensions (mm)**



| Bore mm | A    | B | C  | D 0/-0.03 | E    | F  | G  | H    | I    | J    | K  | L    | M    | N    | O    | P    | Q    | R  | S  | T  |
|---------|------|---|----|-----------|------|----|----|------|------|------|----|------|------|------|------|------|------|----|----|----|
| 12      | 15,4 | 3 | 6  | 7         | 26,3 | 9  | 20 | 7,5  | 10,2 | 23,5 | 28 | 20   | 32,9 | 21,5 | 10,2 | 16   | 39   | 10 | 16 | 22 |
| 16      | 17,5 | 3 | 8  | 9         | 31,1 | 14 | 24 | 7,5  | 12   | 22   | 34 | 22,5 | 35   | 25   | 14   | 18   | 42,5 | 14 | 22 | 26 |
| 20      | 22   | 4 | 10 | 12        | 40,1 | 18 | 30 | 8    | 13   | 25   | 45 | 25   | 39,5 | 32,5 | 16   | 19   | 50   | 16 | 26 | 35 |
| 25      | 26   | 5 | 12 | 14        | 47,9 | 21 | 36 | 8,5  | 18   | 28   | 52 | 28,5 | 45,5 | 38,5 | 20   | 21,5 | 58   | 20 | 32 | 40 |
| 32      | 30   | 6 | 14 | 18        | 55,1 | 24 | 44 | 10,5 | 24   | 34   | 60 | 37,5 | 54   | 44   | 26   | 30   | 68   | 26 | 40 | 46 |

| Bore mm | UU            | VV            | WW            | XX           | YY | Z  | ZZ  |
|---------|---------------|---------------|---------------|--------------|----|----|-----|
| 12      | M3 x 5 depth  | M3 x 5 depth  | M3 x 5 depth  | M3 x 5 depth | M3 | 5  | 2,5 |
| 16      | M4 x 7 depth  | M4 x 7 depth  | M4 x 7 depth  | M5 x 5 depth | M3 | 6  | 3   |
| 20      | M5 x 8 depth  | M5 x 8 depth  | M5 x 8 depth  | M5 x 5 depth | M4 | 7  | 3,5 |
| 25      | M6 x 10 depth | M6 x 10 depth | M6 x 10 depth | M5 x 5 depth | M5 | 9  | 4   |
| 32      | M6 x 10 depth | M6 x 10 depth | M6 x 10 depth | M5 x 5 depth | M6 | 10 | 5   |

**Order Key Code**



**Note :** All grippers are supplied magnetic for optional sensing

**P5GA - Angular Grippers**

| Bore mm | Order code      |
|---------|-----------------|
| 12      | P5GA-012MSG030B |
| 16      | P5GA-016MSG030B |
| 20      | P5GA-020MSG030B |
| 25      | P5GA-025MSG030B |
| 32      | P5GA-032MSG030B |

## P8S Sensors Series

The P8S family of sensors provides a broad range of reed and solid state sensor types with flying lead or M8 options available. Mounting on all grippers is within the integrated sensor grooves allowing for compact installation.

### Electronic sensors

The electronic sensors utilise "Solid State" technology, providing operation with no moving parts. These switches are available in NPN and PNP type, both provide built in short circuit and transient protection as standard. The solid state operation allows for high switching on off frequency, ideal for applications where long service life is required.

#### Technical data

|                            |   |
|----------------------------|---|
| Design                     | GMR (Giant Magnetic Resistance)<br>magneto-resistive function |
| Installation               | Mounts within cylinder switch groove                          |
| Outputs                    | PNP or NPN, normally open                                     |
| Voltage range              | 5-30 V DC   |
| Voltage drop               | 1.5 V max   |
| Switching current          | 50 mA max   |
| Switch rating              | 1.5 W max   |
| Leakage current            | 0.01 mA max   |
| Internal consumption       | 10 mA max (NPN)<br>12 mA max (PNP)                            |
| On/off switching frequency | 1000 Hz max   |
| Encapsulation              | IP 67 (NEMA 6)  |
| Temperature range          | -10°C to +70°C  |
| Indication                 | LED Red (NPN)<br>LED Green (PNP)                              |
| Cable                      | Polyurethane  |

### Reed sensors

Reed type sensors are based on proven reed switch technology and provide reliable function in many applications. Simple installation and the available AC voltage range are advantages for this range of sensors.

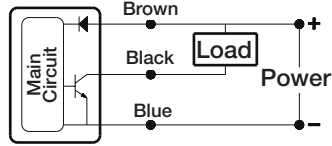
#### Technical data

|                   |                                      |
|-------------------|--------------------------------------|
| Design            | Reed element                         |
| Installation      | Mounts within cylinder switch groove |
| Outputs           | Normally open                        |
| Voltage range     | 5-120 V DC/AC                        |
| Voltage drop      | 2.5 V max                            |
| Switching current | 100 mA max                           |
| Switch rating     | 10 W max                             |
| Encapsulation     | IP 67 (NEMA 6)                       |
| Temperature range | -10°C to +70°C                       |
| Indication        | LED Red                              |
| Cable             | Polyurethane                         |

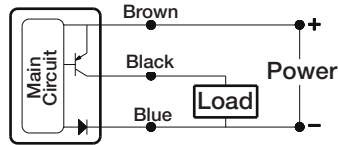
**Electronic sensors**

**Schematic**

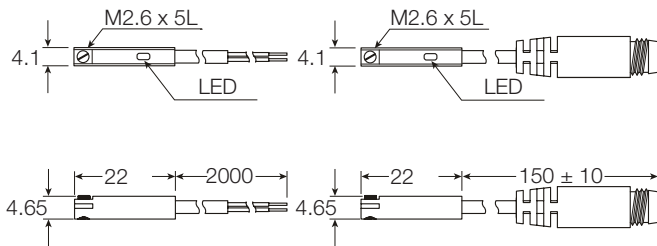
NPN type



PNP type



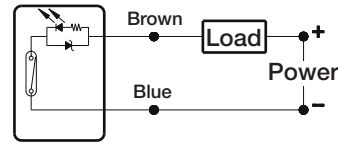
**Dimensions**



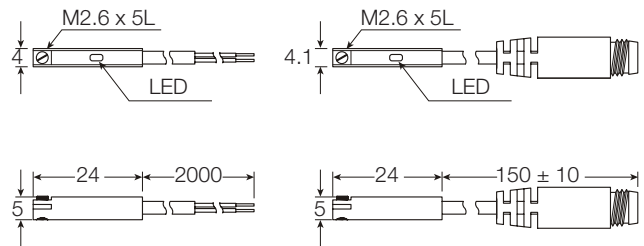
**Reed sensors**

**Schematic**

Reed type

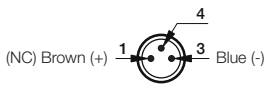


**Dimensions**

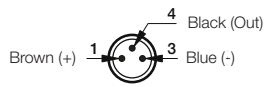


**M8 Quick Connector**

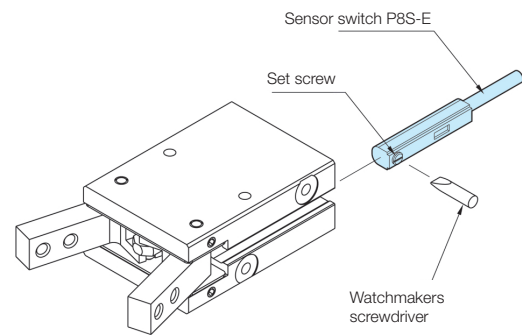
2 wire QC wiring



3 wire QC wiring



**Installation of Sensor**



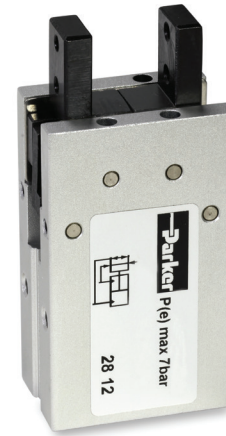
**Electronic and Reed Sensors**

| Size                     | Description                               | Order code       |
|--------------------------|---|------------------|
| <b>Flush Mount Style</b> |   |                  |
| PNP Type, normally open  | 0.165 m cable and M8 screw male connector | <b>P8S-EPSUS</b> |
| PNP Type, normally open  | 2 m PUR cable without connector           | <b>P8S-EPFXS</b> |
| NPN Type, normally open  | 0.165 m cable and M8 screw male connector | <b>P8S-ENSUS</b> |
| NPN Type, normally open  | 2 m PUR cable without connector           | <b>P8S-ENFXS</b> |
| Reed Type, normally open | 0.15 m cable and M8 screw male connector  | <b>P8S-ERSUS</b> |
| Reed Type, normally open | 2 m PUR cable without connector           | <b>P8S-ERFXS</b> |

**P5GB - Parallel double acting,  
square jaw carriers**

Available with a comprehensive range of bore sizes Ø12 - 32 mm the P5GB double acting parallel gripper is an accurate workpiece holding device. The anodised aluminium body has flexible installation mountings on three sides and recessed sensor grooves.

- Bore sizes Ø12, 16, 20, 25 and 32 mm
- Double acting
- Anodised corrosion protection
- Magnetic piston as standard
- Optional sensors

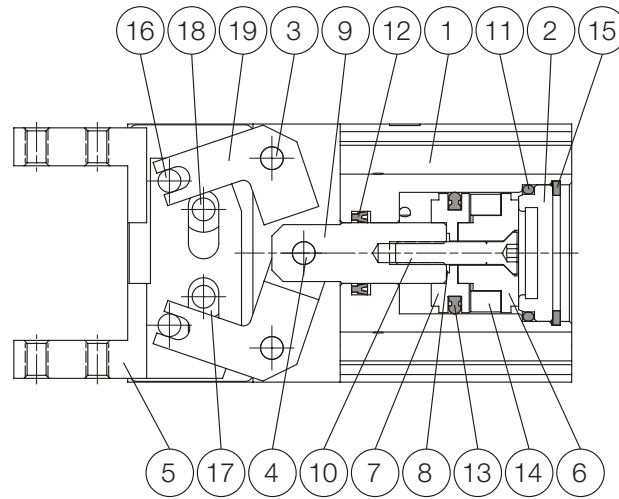


**General technical data**

| Size                                       | 12                                  | 16   | 20   | 25   | 32   |
|--|-------------------------------------|------|------|------|------|
| Total stroke (mm)                          | 6                                   | 8    | 12   | 14   | 16   |
| Total Force* (N) - Closed side             | 10                                  | 26   | 70   | 120  | 170  |
| Total Force* (N) - Open side               | 16                                  | 48   | 94   | 140  | 200  |
| Ø Piston bore (mm)                         | 12                                  | 16   | 20   | 25   | 32   |
| Ø Air port size (mm)                       | M3                                  | M5   |      |      |      |
| Air consumption (cm <sup>3</sup> cycle) ** | 0.7                                 | 3    | 7    | 14   | 21   |
| Repeatability (mm)                         | ± 0.04                              |      |      |      |      |
| Max. work frequency (Hz)                   | 3                                   |      |      |      |      |
| Min. closing time (s)                      | 0.015                               | 0.02 | 0.05 | 0.07 | 0.09 |
| Weight (g)                                 | 66                                  | 144  | 255  | 419  | 719  |
| Max. jaw length (mm)                       | 30                                  | 40   | 60   | 70   | 85   |
| Max. temperature (°C)                      | -5° to +60°                         |      |      |      |      |
| Air pressure (bar)                         | 1.5 to 7                            |      |      |      |      |
| Operation                                  | Dry air, lubricated or unlubricated |      |      |      |      |

\* At 5 bar, L=30mm.

\*\* Cycle = opening + closing (without jaws)



| Pos | Part                   | Specification       |
|-----|------------------------|---------------------|
| 1   | Body                   | Aluminium alloy     |
| 2   | Sealing cap            | Aluminium alloy     |
| 3   | Lever spindle          | Medium carbon steel |
| 4   | Retaining pin          | Bearing steel       |
| 5   | Jaw carrier            | Medium carbon steel |
| 6   | Lower piston half      | Aluminium alloy     |
| 7   | Upper piston half      | Aluminium alloy     |
| 8   | Gasket                 | NBR                 |
| 9   | Piston rod             | Stainless steel     |
| 10  | Piston retaining screw | Stainless steel     |
| 11  | O ring                 | NBR                 |
| 12  | U cup                  | NBR                 |

| Pos | Part               | Specification               |
|-----|--------------------|-----------------------------|
| 13  | Piston seal        | NBR                         |
| 14  | Magnet             | Magnetic material           |
| 15  | Circlip            | Spring steel                |
| 16  | Lever pin          | Bearing steel               |
| 17  | Guide plate        | Stainless steel             |
| 18  | Jaw spindle        | Medium carbon steel         |
| 19  | Lever              | Medium carbon steel         |
| 20  | Set screw          | SCM (Not shown)             |
| 21  | Set screw          | SCM (Not shown)             |
| 22  | Washer for gripper | Stainless steel (Not shown) |
|     | Note on materials  | RoHS Compliant              |

**How to select the correct model (or required clamp force) according to the weight of workpiece.**

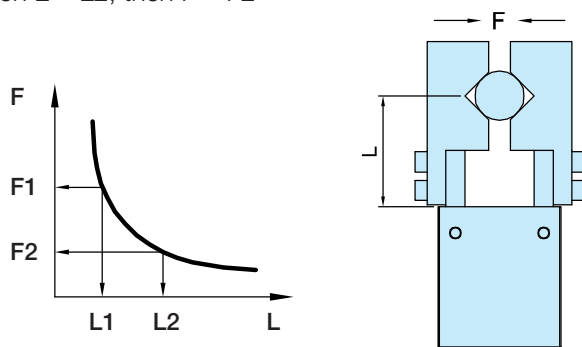
The friction coefficient of the workpiece will be influenced by the shape and shifting condition but in connection with the weight of workpiece, the safety factor of clamping force is as shown below. Please select your model according to the result of below calculation.

- Clamp force only W: (FxN) = 1:5
- Shifting under normal condition W: (FxN) = 1:10
- Shifting under acceleration W: (FxN) = 1:20

To obtain gripping power from performance data, if the distance to the workpiece's center of gravity is L when manufacturing the small jaw, gripping power F is expressed as follows

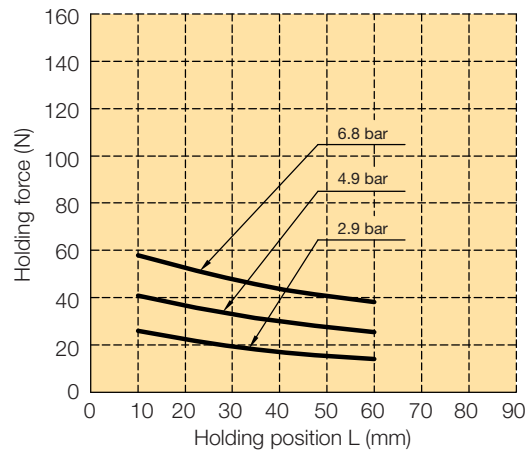
When L = L1, then F = F1

When L = L2, then F = F2

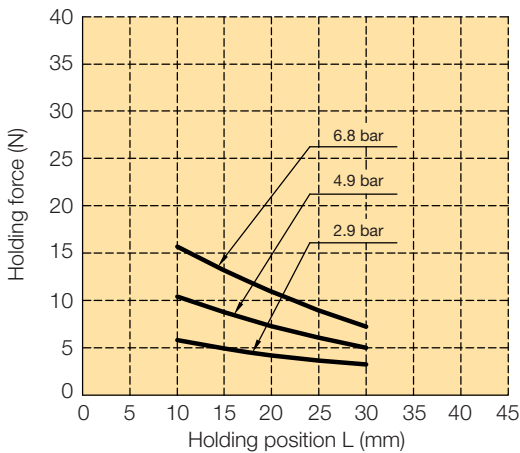


W = Weight of workpiece  
 F : Clamp force per jaw  
 (Please refer to clamp force performance chart)  
 N : Number of finger blanks

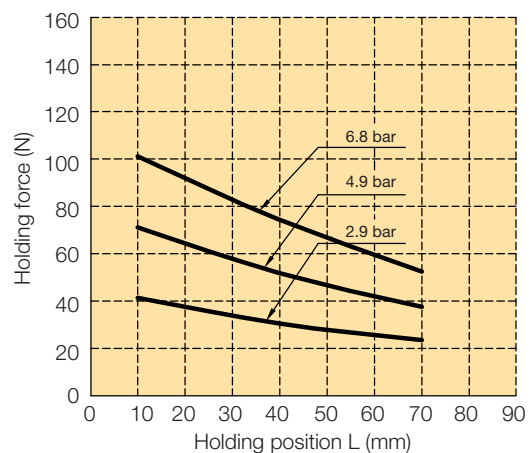
**P5GB-020MSG012B**



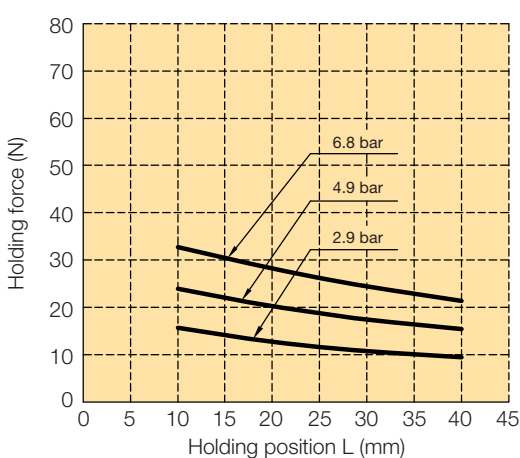
**P5GB-012MSG006B**



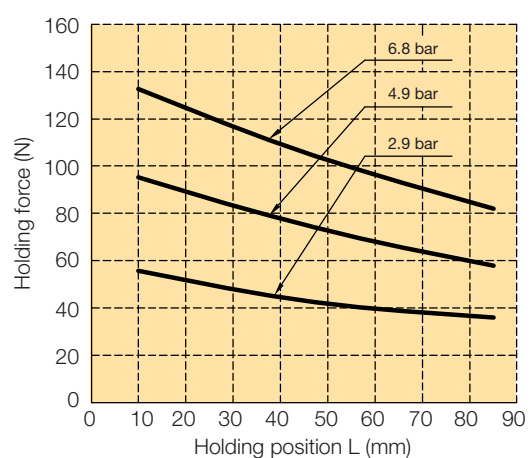
**P5GB-025MSG014B**



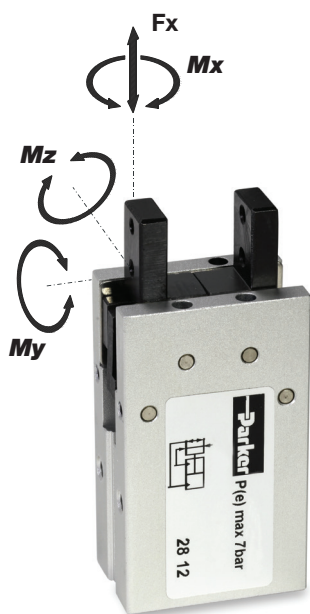
**P5GB-016MSG008B**



**P5GB-032MSG016B**



**P5GB - Permissible force and torques on jaw carriers**



**Static**

| Size | 12     | 16      | 20      | 25 & 32 |
|------|--------|---------|---------|---------|
| Fx   | 30N    | 50N     | 75N     | 125N    |
| Mx   | 0,26Nm | 0,67 Nm | 1,32 Nm | 1,94 Nm |
| My   | 0,26Nm | 0,67 Nm | 1,32 Nm | 1,94 Nm |
| Mz   | 0,26Nm | 0,67 Nm | 1,32 Nm | 1,94 Nm |

**Mass of one of the 2 jaws (g) / closing and opening time (s) :**

| Size    | 12  | 16  | 20   | 25 & 32 |
|---------|-----|-----|------|---------|
| m 0,2s  | 40g | 80g | 150g | 250g    |
| m 0,07s | 25g | 45g | 75g  | 100g    |
| m 0,05s | 20g | 35g | 50g  | -       |
| m 0,02s | 15g | 25g | -    | -       |
| m 0,01s | 10g | -   | -    | -       |

m is the permissible mass of the jaw for using gripper without flow controllers. If the mass of jaw is higher, use flow controllers to reduce the jaw-carriers speed.

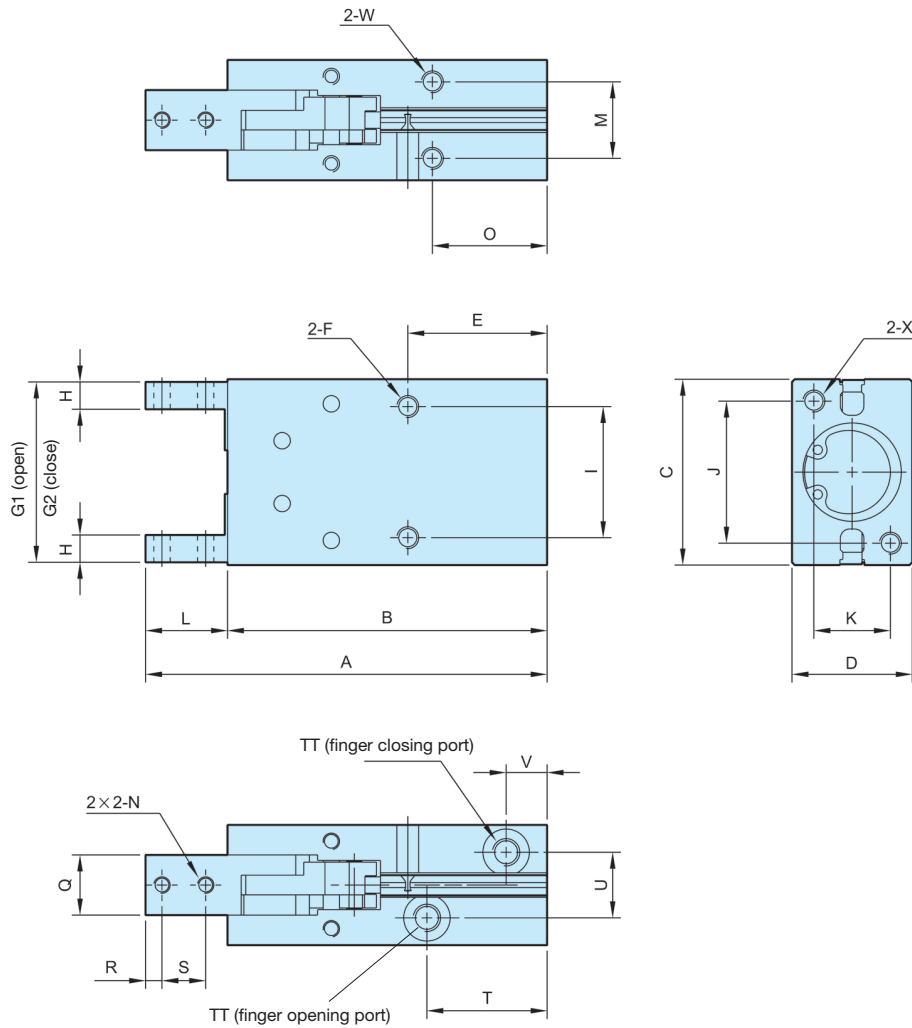
m 0,2 s gives the max. mass of jaw to fix on one of the jaw-carriers for a 0,2 s closing time.

These indications must not be exceeded if:

- any extra forces are exerted on the workpiece or the jaws, in addition to the force of the clamping torque.
- handling forces (acceleration, shocks..) must also be added.

These values are cumulative if the forces act in different directions at the same time.

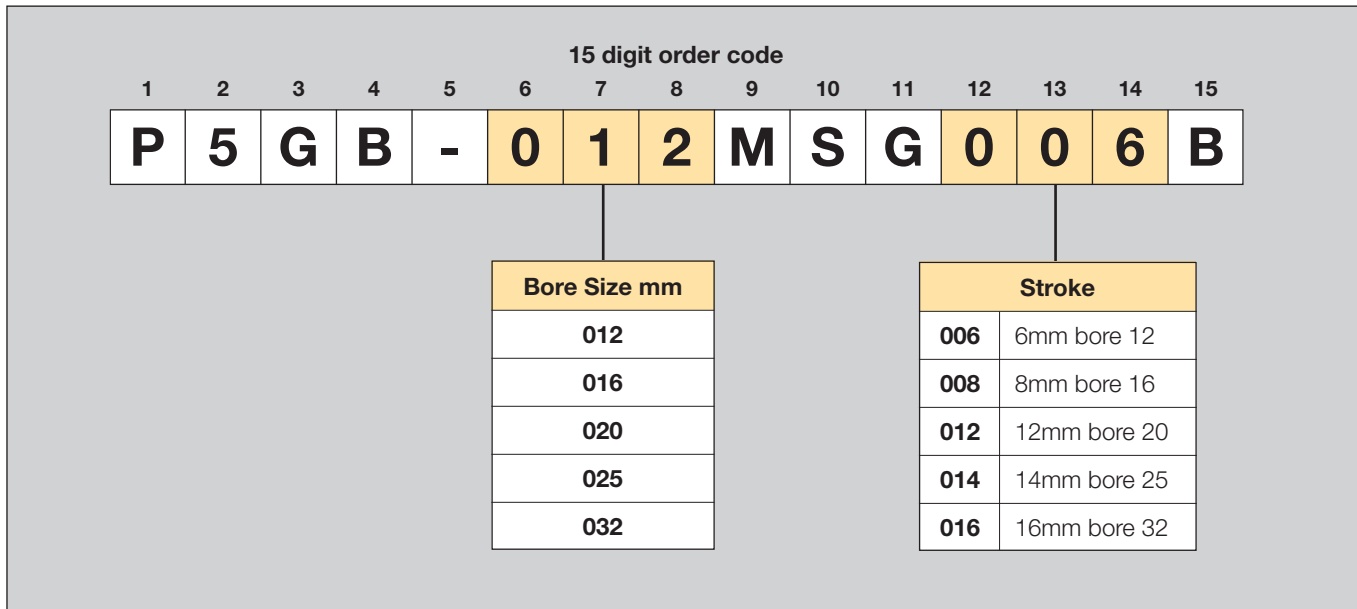
**Dimensions (mm)**



| Bore mm | A     | B    | C  | D  | E    | F                   | G1 | G2 | H  | I  | J  | K  | L  | M  | N        | O  | Q 0/-0.03 | R |
|---------|-------|------|----|----|------|---------------------|----|----|----|----|----|----|----|----|----------|----|-----------|---|
| 12      | 63,5  | 50,5 | 28 | 16 | 20   | M3 x 0.5 x 5 depth  | 27 | 21 | 4  | 18 | 17 | 10 | 13 | 10 | M3 x 0.5 | 16 | 7         | 3 |
| 16      | 73,5  | 58,5 | 34 | 22 | 25,5 | M4 x 0.7 x 11 depth | 33 | 25 | 5  | 24 | 26 | 14 | 15 | 14 | M3 x 0.5 | 21 | 11        | 3 |
| 20      | 88,5  | 69,5 | 45 | 26 | 25   | M5 x 0.8 x 8 depth  | 44 | 32 | 6  | 30 | 35 | 16 | 19 | 16 | M4 x 0.7 | 19 | 12        | 4 |
| 25      | 102,5 | 78,5 | 52 | 32 | 28   | M6 x 1.0 x 10 depth | 51 | 37 | 8  | 36 | 40 | 20 | 24 | 20 | M5 x 0.8 | 22 | 14        | 5 |
| 32      | 120,5 | 90,5 | 60 | 40 | 34   | M6 x 1.0 x 10 depth | 59 | 43 | 10 | 44 | 46 | 24 | 30 | 26 | M6 x 1.0 | 26 | 20        | 7 |

| Bore mm | S  | T  | TT                 | U    | V    | W                   | X                   |
|---------|----|----|--------------------|------|------|---------------------|---------------------|
| 12      | 6  | 23 | M5 x 0,8 x 5 depth | 10,2 | 7,5  | M3 x 0.5 x 5 depth  | M3 x 0.5 x 5 depth  |
| 16      | 8  | 22 | M5 x 0,8 x 5 depth | 12   | 7,5  | M4 x 0.7 x 7 depth  | M4 x 0.7 x 7 depth  |
| 20      | 10 | 26 | M5 x 0,8 x 5 depth | 13   | 8    | M5 x 0.8 x 8 depth  | M5 x 0.8 x 8 depth  |
| 25      | 12 | 29 | M5 x 0,8 x 5 depth | 18   | 8,5  | M6 x 1.0 x 10 depth | M6 x 1.0 x 10 depth |
| 32      | 15 | 35 | M5 x 0,8 x 5 depth | 24   | 10,5 | M6 x 1.0 x 10 depth | M6 x 1.0 x 10 depth |

**Order Key Code**



**Note :** All grippers are supplied magnetic for optional sensing

**P5GB - Parallel Grippers**

| Bore mm | Order code      |
|---------|-----------------|
| 12      | P5GB-012MSG006B |
| 16      | P5GB-016MSG008B |
| 20      | P5GB-020MSG012B |
| 25      | P5GB-025MSG014B |
| 32      | P5GB-032MSG016B |

**P8S Sensors Series**

The P8S family of sensors provides a broad range of reed and solid state sensor types with flying lead or M8 options available. Mounting on all grippers is within the integrated sensor grooves allowing for compact installation.

**Electronic sensors**

The electronic sensors utilise “Solid State” technology, providing operation with no moving parts. These switches are available in NPN and PNP type, both provide built in short circuit and transient protection as standard. The solid state operation allows for high switching on off frequency, ideal for applications where long service life is required.

**Technical data**

|                            |   |
|----------------------------|---|
| Design                     | GMR (Giant Magnetic Resistance)<br>magneto-resistive function |
| Installation               | Mounts within cylinder switch groove                          |
| Outputs                    | PNP or NPN, normally open                                     |
| Voltage range              | 5-30 V DC   |
| Voltage drop               | 1.5 V max   |
| Switching current          | 50 mA max   |
| Switch rating              | 1.5 W max   |
| Leakage current            | 0.01 mA max   |
| Internal consumption       | 10 mA max (NPN)<br>12 mA max (PNP)                            |
| On/off switching frequency | 1000 Hz max   |
| Encapsulation              | IP 67 (NEMA 6)  |
| Temperature range          | -10°C to +70°C  |
| Indication                 | LED Red (NPN)<br>LED Green (PNP)                              |
| Cable                      | Polyurethane  |

**Reed sensors**

Reed type sensors are based on proven reed switch technology and provide reliable function in many applications. Simple installation and the available AC voltage range are advantages for this range of sensors.

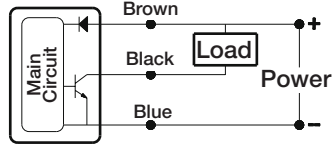
**Technical data**

|                   |                                      |
|-------------------|--------------------------------------|
| Design            | Reed element                         |
| Installation      | Mounts within cylinder switch groove |
| Outputs           | Normally open                        |
| Voltage range     | 5-120 V DC/AC                        |
| Voltage drop      | 2.5 V max                            |
| Switching current | 100 mA max                           |
| Switch rating     | 10 W max                             |
| Encapsulation     | IP 67 (NEMA 6)                       |
| Temperature range | -10°C to +70°C                       |
| Indication        | LED Red                              |
| Cable             | Polyurethane                         |

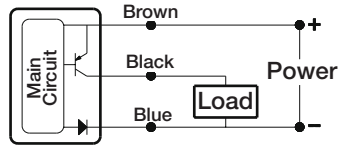
**Electronic sensors**

**Schematic**

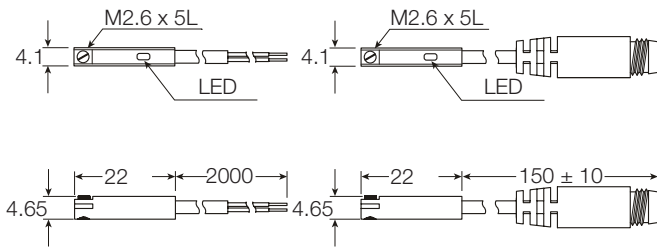
**NPN type**



**PNP type**



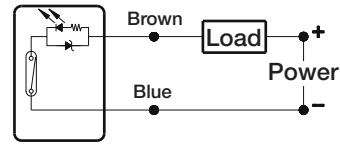
**Dimensions**



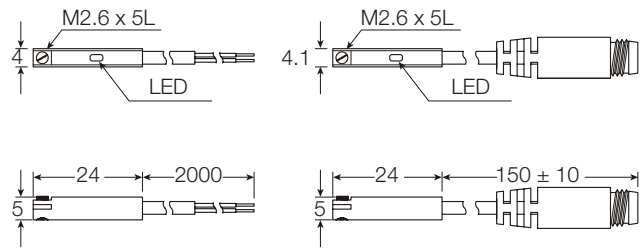
**Reed sensors**

**Schematic**

**Reed type**

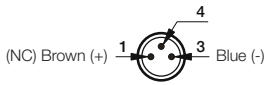


**Dimensions**

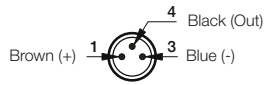


**M8 Quick Connector**

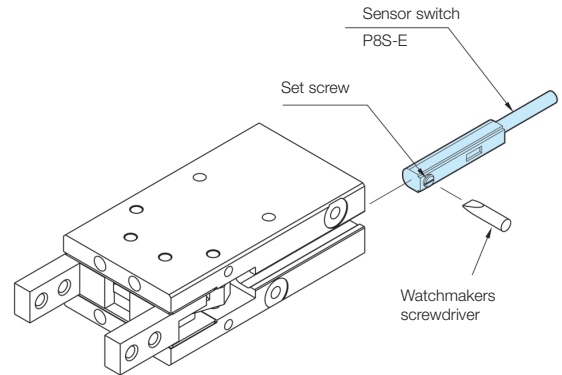
**2 wire**



**3 wire**



**Installation of Sensor**

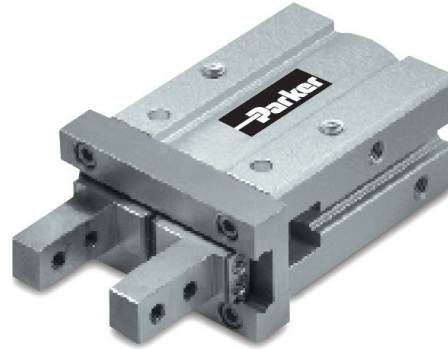


**Electronic and Reed Sensors**

| Size                     | Description                               | Order code       |
|--------------------------|---|------------------|
| <b>Flush Mount Style</b> |   |                  |
| PNP Type, normally open  | 0.165 m cable and M8 screw male connector | <b>P8S-EPSUS</b> |
| PNP Type, normally open  | 2 m PUR cable without connector           | <b>P8S-EPFXS</b> |
| NPN Type, normally open  | 0.165 m cable and M8 screw male connector | <b>P8S-ENSUS</b> |
| NPN Type, normally open  | 2 m PUR cable without connector           | <b>P8S-ENFXS</b> |
| Reed Type, normally open | 0.15 m cable and M8 screw male connector  | <b>P8S-ERSUS</b> |
| Reed Type, normally open | 2 m PUR cable without connector           | <b>P8S-ERFXS</b> |

### P5GD - Parallel precision guided double acting, square jaw carriers

The P5GD is a parallel double acting gripper with integral linear guides that provide rigidity and high precision for the stainless steel jaw carriers. The anodised aluminium body has mounting points on four sides and integral sensors grooves.



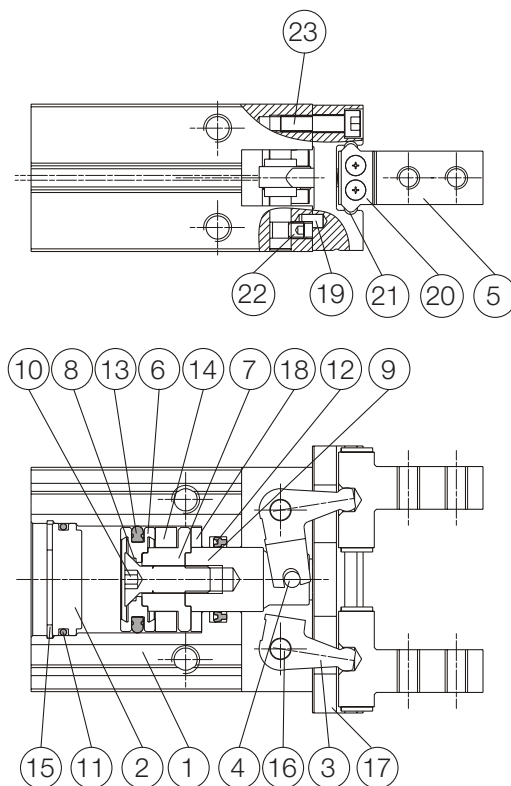
- Bore sizes Ø 10, 16, 20 and 25 mm
- Double acting
- Stainless steel jaw carriers
- Anodised corrosion protection
- Magnetic piston as standard
- Optional sensors

#### General technical data

| Size                                       | 10                                  | 16       | 20   | 25   |
|--|-------------------------------------|----------|------|------|
| Total stroke (mm)                          | 4                                   | 6        | 10   | 14   |
| Total Force* (N) - Closed side             | 22                                  | 68       | 94   | 130  |
| Total Force* (N) - Open side               | 34                                  | 90       | 132  | 208  |
| Ø Piston bore (mm)                         | 10                                  | 16       | 20   | 25   |
| Ø Port size (mm)                           | M3                                  | M5       |      |      |
| Air consumption (cm <sup>3</sup> cycle) ** | 0.5                                 | 2        | 6    | 14   |
| Repeatability (mm)                         | ± 0.01                              |          |      |      |
| Max. work frequency (Hz)                   | 3                                   |          |      |      |
| Min. closing time (s)                      | 0.015                               | 0.02     | 0.05 | 0.07 |
| Weight (g)                                 | 55                                  | 125      | 250  | 460  |
| Max. jaw length (mm)                       | 50                                  | 55       | 80   | 100  |
| Max. temperature (°C)                      | -10° to +60°                        |          |      |      |
| Pressure (bar)                             | 2 to 7                              | 1.5 to 7 |      |      |
| Operation                                  | Dry air, lubricated or unlubricated |          |      |      |

\* At 5 bar, L=20mm.

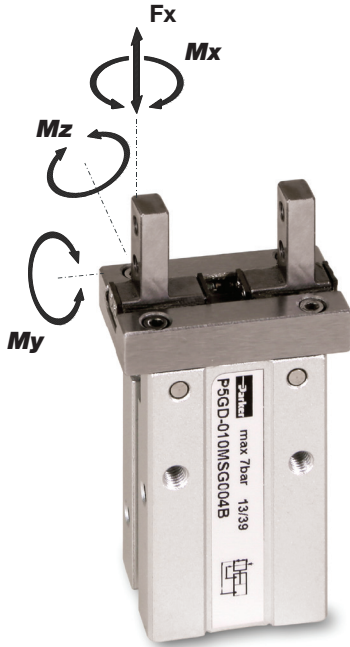
\*\* Cycle = opening + closing (without jaws)



| Pos | Part                   | Specification   |
|-----|------------------------|-----------------|
| 1   | Body                   | Aluminium alloy |
| 2   | Sealing cap            | Aluminium alloy |
| 3   | Lever                  | Stainless steel |
| 4   | Retaining pin          | Carbon steel    |
| 5   | Jaw carrier            | Stainless steel |
| 6   | Lower piston half      | Aluminium alloy |
| 7   | Upper piston half      | Aluminium alloy |
| 8   | Gasket                 | NBR             |
| 9   | Piston rod             | Stainless steel |
| 10  | Piston retaining screw | Stainless steel |
| 11  | O ring                 | NBR             |
| 12  | U cup                  | NBR             |

| Pos | Part              | Specification     |
|-----|-------------------|-------------------|
| 13  | Piston seal       | NBR               |
| 14  | Magnet            | Magnetic material |
| 15  | Circlip           | Spring steel      |
| 16  | Lever pin         | Bearing steel     |
| 17  | Guide plate       | Stainless steel   |
| 18  | Buffer            | PU                |
| 19  | Pin               | Carbon steel      |
| 20  | Roller stopper    | Stainless steel   |
| 21  | Steel ball        | Stainless steel   |
| 22  | Screw             | Carbon steel      |
| 23  | Screw             | Stainless steel   |
|     | Note on materials | RoHS Compliant    |

**P5GD - Permissible force and torques on jaw carriers**



**Static**

| Size | 10      | 16      | 20      | 25      |
|------|---------|---------|---------|---------|
| Fx   | 60 N    | 100 N   | 150 N   | 255 N   |
| Mx   | 0.26 Nm | 0.68 Nm | 1.32 Nm | 1.94 Nm |
| My   | 0.53 Nm | 1.36 Nm | 2.65 Nm | 3.88 Nm |
| Mz   | 0.26 Nm | 0.68 Nm | 1.32 Nm | 1.94 Nm |

**Mass of one of the 2 jaws (g) / closing and opening time (s) :**

| Size     | 10   | 16   | 20    | 25    |
|----------|------|------|-------|-------|
| m 0.2 s  | 40 g | 80 g | 150 g | 250 g |
| m 0.07 s | 25 g | 45 g | 75 g  | 100 g |
| m 0.05 s | 20 g | 35 g | 50 g  | -     |
| m 0.02 s | 15 g | 25 g | -     | -     |
| m 0.01 s | 10 g | -    | -     | -     |

m is the permissible mass of the jaw for using gripper without flow controllers. If the mass of jaw is higher, use flow controllers to reduce the jaw-carriers speed.

m 0.2 s gives the max. mass of jaw to fix on one of the jaw-carriers for a 0.2 s closing time.

These indications must not be exceeded if:

- any extra forces are exerted on the workpiece or the jaws, in addition to the force of the clamping torque.
- handling forces (acceleration, shocks..) must also be added.

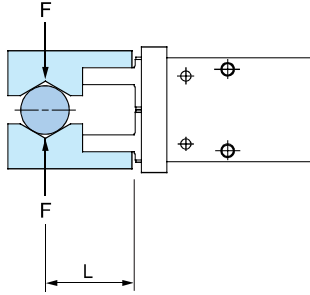
These values are cumulative if the forces act in different directions at the same time.

| Calculate of allowable external force (when moment load is applied)  | Calculation example  |
|--|--|
| $\text{Allowable load } F \text{ (N)} = \frac{M \text{ (maximum allowable moment) (N.m)}}{L \times 10^{-3} \text{ (*)}}$ <p>(* Unit conversion constant)</p> | <p>When a static load of <math>f = 10\text{N}</math> is operating, which applies pitch moment point<br/> <math>L = 30\text{mm}</math> from the P5GD-016MSG006B guide</p> $\text{Allowable load } F = \frac{0.68}{30 \times 10^{-3}} = 22.7 \text{ (N)}$ <p><b>Load <math>f = 10 \text{ (N)} &lt; 22.7 \text{ (N)}</math></b></p> <p>Therefore, it can be used.</p> |

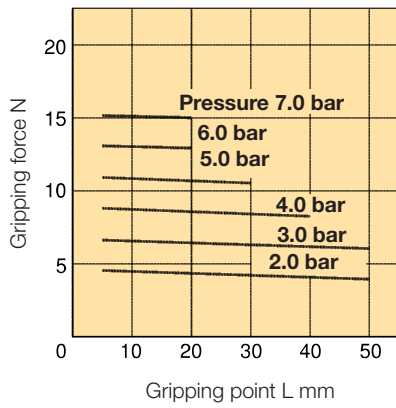
**Effective gripping force: Double acting / External gripping force**

**Expressing the effective gripping force.**

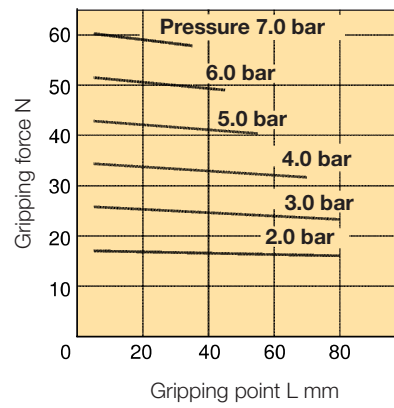
The effective gripping force shown in the graphs below is expressed as  $F$ , which is the impellent force of one finger, when both fingers and attachments are in full contact with the work piece as shown in the figure below.



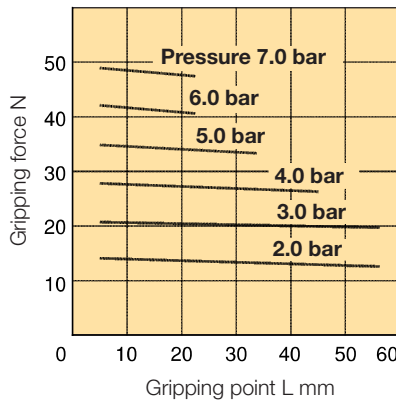
**Size 10**



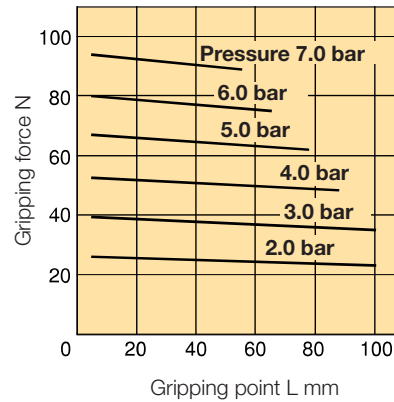
**Size 20**



**Size 16**



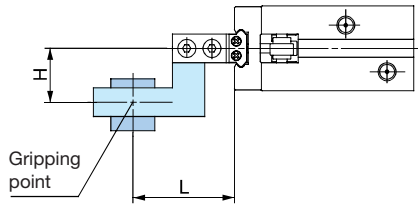
**Size 25**



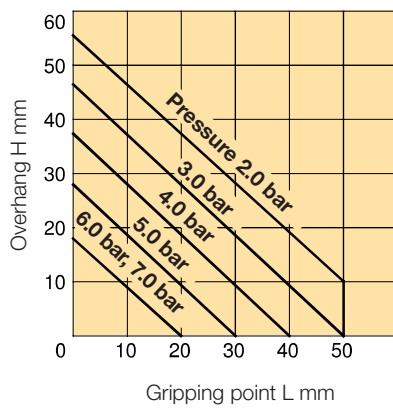
**Confirmation of gripping point: External gripping**

The air gripper should be operated so that the work piece gripping point "L" and the amount of overhang "H" stay within the range shown for each operating pressure given in the graphs below.

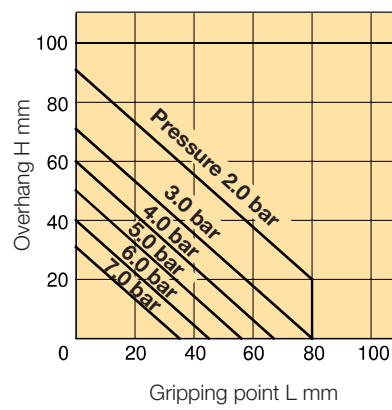
If the work piece gripping point goes beyond the range limits, this will have an adverse effect on the life of the air gripper.



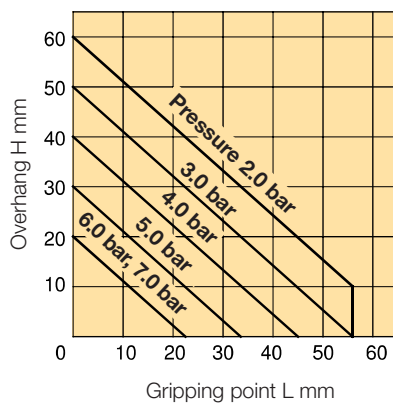
**Size 10**



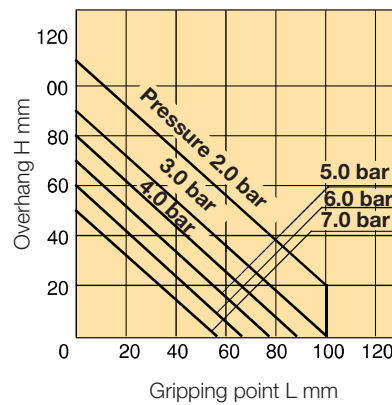
**Size 20**



**Size 16**



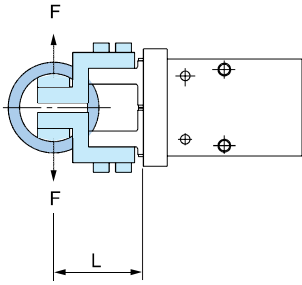
**Size 25**



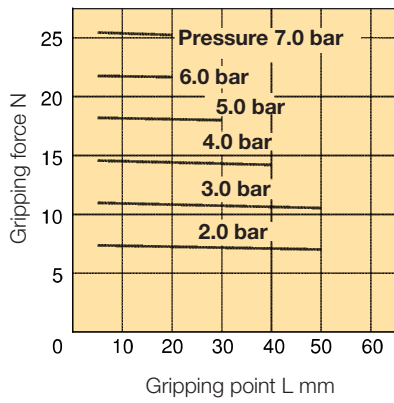
**Effective gripping force: Double acting / Internal gripping force**

**Expressing the effective gripping force.**

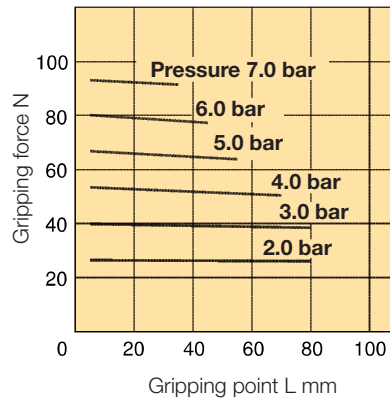
The effective gripping force shown in the graphs below is expressed as F, which is the impellent force of one finger, when both fingers and attachments are in full contact with the work piece as shown in the figure below.



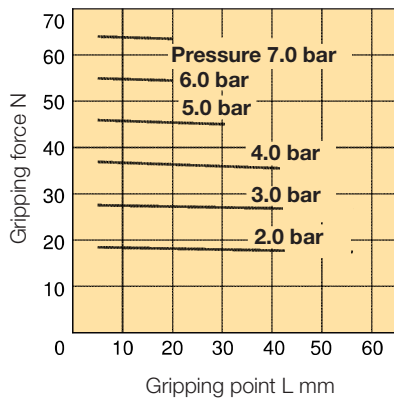
**Size 10**



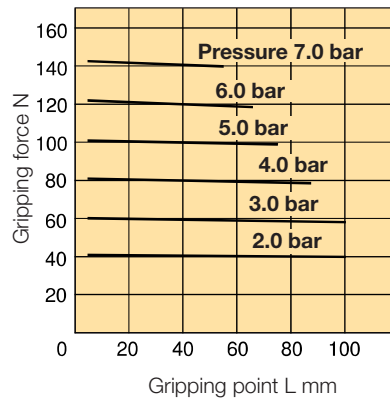
**Size 20**



**Size 16**



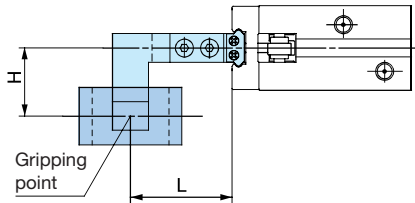
**Size 25**



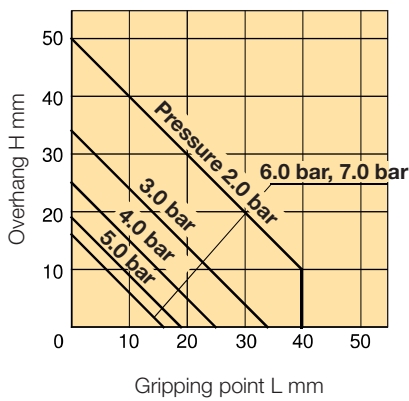
**Confirmation of gripping point: Internal gripping**

The air gripper should be operated so that the work piece gripping point "L" and the amount of overhang "H" stay within the range shown for each operating pressure given in the graphs below.

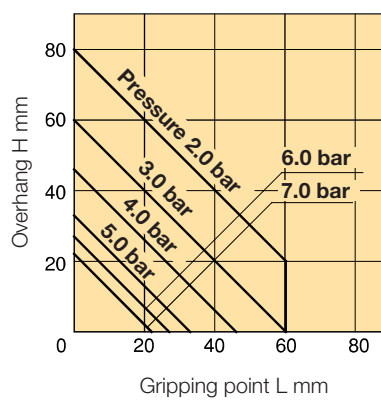
If the work piece gripping point goes beyond the range limits, this will have an adverse effect on the life of the air gripper.



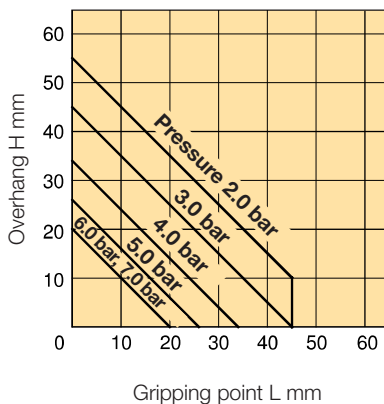
**Size 10**



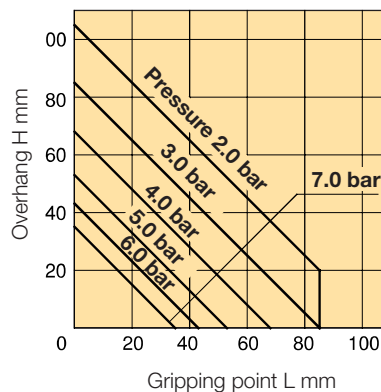
**Size 20**



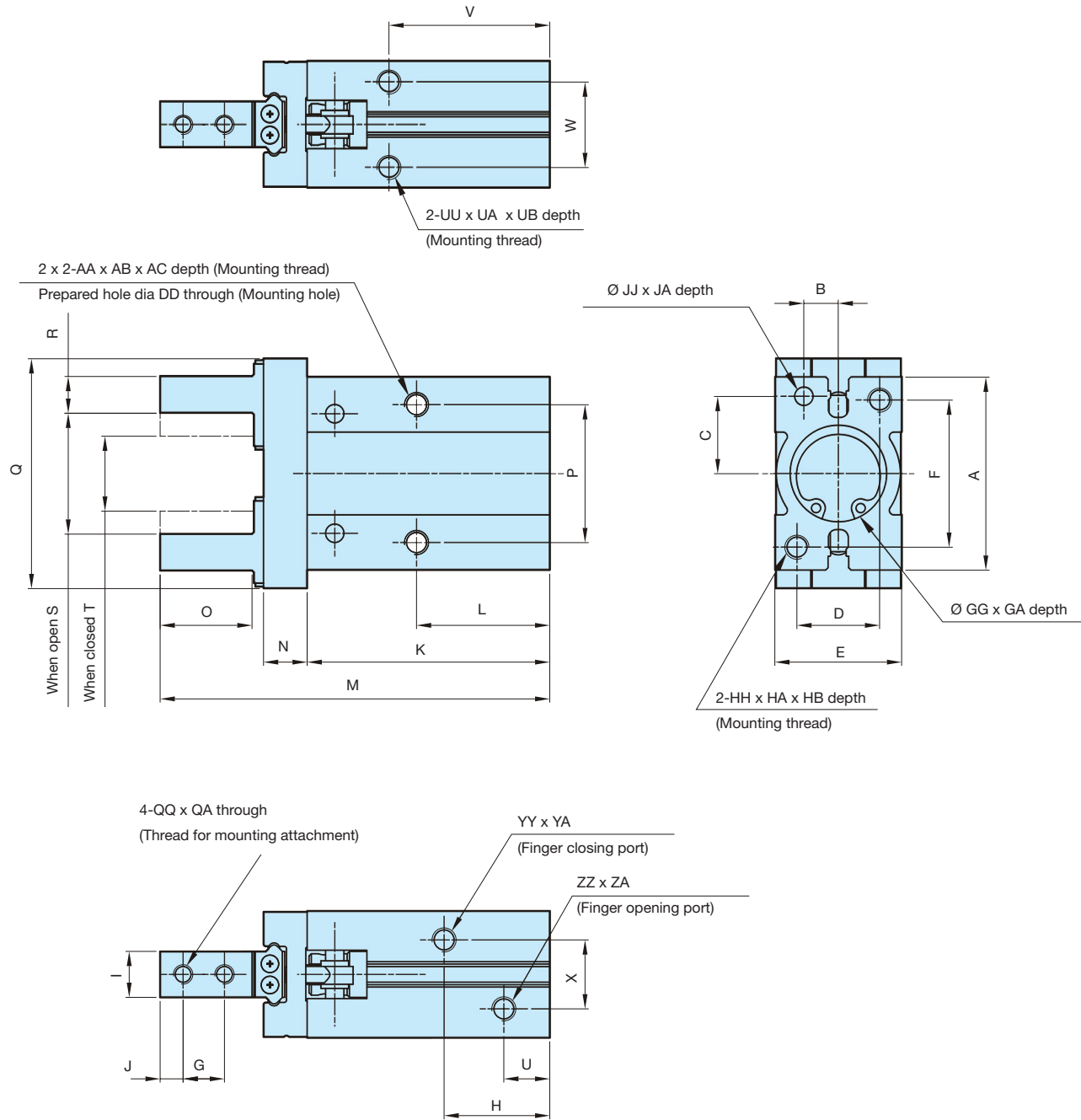
**Size 16**



**Size 25**

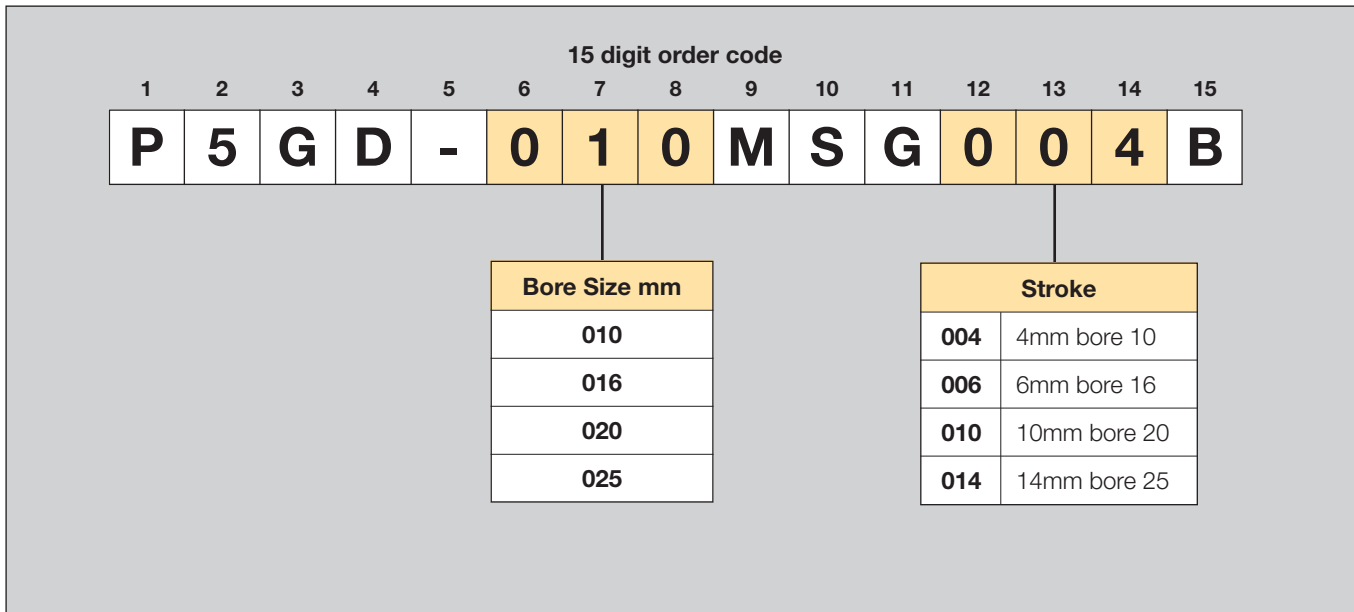


**Dimensions (mm)**



| Bore mm | A    | AA | AB  | AC  | B                                    | C                                      | D                               | DD                                   | E                                      | F   | G   | GG                                   | GA  | H    | HH   | HA  | HB | I                                | J  | JJ                                    | JA | K    | L    | M     |
|---------|------|----|-----|-----|--------------------------------------|--|---------------------------------|--------------------------------------|--|-----|-----|--------------------------------------|-----|------|------|-----|----|----------------------------------|----|---------------------------------------|----|------|------|-------|
| 10      | 23   | M3 | 0.5 | 5.5 | 5.2 <sup>+0.025</sup> <sub>-0</sub>  | 7.6 <sup>+0.02</sup> <sub>-0.02</sub>  | 12                              | 2.6                                  | 16.4 <sup>+0.05</sup> <sub>-0.05</sub> | 18  | 5.7 | 11H9 <sup>+0.043</sup> <sub>-0</sub> | 2   | 19   | M3   | 0.5 | 6  | 5 <sup>0</sup> <sub>-0.05</sub>  | 3  | 2H9 <sup>+0.025</sup> <sub>-0</sub>   | 3  | 37.8 | 23   | 57    |
| 16      | 30.6 | M4 | 0.7 | 8   | 6.5 <sup>+0.025</sup> <sub>-0</sub>  | 11 <sup>+0.02</sup> <sub>-0.02</sub>   | 15                              | 3.4                                  | 23.6 <sup>+0.05</sup> <sub>-0.05</sub> | 22  | 7   | 17H9 <sup>+0.043</sup> <sub>-0</sub> | 2   | 19   | M4   | 0.7 | 8  | 8 <sup>0</sup> <sub>-0.05</sub>  | 4  | 3H9 <sup>+0.025</sup> <sub>-0</sub>   | 3  | 42.5 | 24.5 | 67.3  |
| 20      | 42   | M5 | 0.8 | 10  | 7.5 <sup>+0.030</sup> <sub>-0</sub>  | 16.8 <sup>+0.02</sup> <sub>-0.02</sub> | 18                              | 3.4                                  | 27.6 <sup>+0.05</sup> <sub>-0.05</sub> | 32  | 9   | 21H9 <sup>+0.052</sup> <sub>-0</sub> | 3   | 23   | M5   | 0.8 | 10 | 10 <sup>0</sup> <sub>-0.05</sub> | 5  | 4H9 <sup>+0.030</sup> <sub>-0</sub>   | 4  | 52.8 | 29   | 84.8  |
| 25      | 52   | M6 | 1   | 12  | 10 <sup>+0.002</sup> <sub>-0.0</sub> | 21.8 <sup>+0.02</sup> <sub>-0.02</sub> | 22                              | 5.1                                  | 33.6 <sup>+0.05</sup> <sub>-0.05</sub> | 40  | 12  | 21H9 <sup>+0.052</sup> <sub>-0</sub> | 3.5 | 23.5 | M6   | 1   | 12 | 12 <sup>0</sup> <sub>-0.05</sub> | 6  | 4H9 <sup>+0.02</sup> <sub>-0.02</sub> | 4  | 63.6 | 30   | 102.7 |
| Bore mm | N    | O  | P   | Q   | QQ                                   | QA                                     | R                               | S                                    | T                                      | U   | UU  | UA                                   | UB  | V    | W    | X   | YY | YA                               | ZZ | ZA                                    |    |      |      |       |
| 10      | 6    | 12 | 16  | 29  | M2.5                                 | 0.45                                   | 4 <sup>0</sup> <sub>-0.1</sub>  | 15.2 <sup>+2.2</sup> <sub>0</sub>    | 11.2 <sup>0</sup> <sub>-0.7</sub>      | 9   | M3  | 0.5                                  | 6   | 27   | 11.4 | 10  | M3 | 0.5                              | M3 | 0.5                                   |    |      |      |       |
| 16      | 7.5  | 15 | 24  | 38  | M3                                   | 0.5                                    | 5 <sup>0</sup> <sub>-0.1</sub>  | 20.9 <sup>+2.2</sup> <sub>-0.2</sub> | 14.9 <sup>0</sup> <sub>-0.7</sub>      | 8.5 | M4  | 0.7                                  | 4.5 | 30   | 16   | 13  | M5 | 0.8                              | M5 | 0.8                                   |    |      |      |       |
| 20      | 9.5  | 20 | 30  | 50  | M4                                   | 0.7                                    | 8 <sup>0</sup> <sub>-0.1</sub>  | 26.3 <sup>+2.2</sup> <sub>-0.2</sub> | 16.3 <sup>0</sup> <sub>-0.7</sub>      | 10  | M5  | 0.8                                  | 8   | 35   | 18.6 | 15  | M5 | 0.8                              | M5 | 0.8                                   |    |      |      |       |
| 25      | 11   | 25 | 36  | 63  | M5                                   | 0.8                                    | 10 <sup>0</sup> <sub>-0.1</sub> | 33.3 <sup>+2.2</sup> <sub>-0.2</sub> | 19.3 <sup>0</sup> <sub>-0.8</sub>      | 9.7 | M6  | 1                                    | 10  | 36.5 | 22   | 20  | M5 | 0.8                              | M5 | 0.8                                   |    |      |      |       |

**Order Key Code**



**Note :** All grippers are supplied magnetic for optional sensing

**P5GD - Parallel Grippers**

| Bore mm | Order code             |
|---------|------------------------|
| 10      | <b>P5GD-010MSG004B</b> |
| 16      | <b>P5GD-016MSG006B</b> |
| 20      | <b>P5GD-020MSG010B</b> |
| 25      | <b>P5GD-025MSG014B</b> |

## P8S Sensors Series

The P8S family of sensors provides a broad range of reed and solid state sensor types with flying lead or M8 options available. Mounting on all grippers is within the integrated sensor grooves allowing for compact installation.

### Electronic sensors

The electronic sensors utilise “Solid State” technology, providing operation with no moving parts. These switches are available in NPN and PNP type, both provide built in short circuit and transient protection as standard. The solid state operation allows for high switching on off frequency, ideal for applications where long service life is required.

#### Technical data

|                            |   |
|----------------------------|---|
| Design                     | GMR (Giant Magnetic Resistance)<br>magneto-resistive function |
| Installation               | Mounts within cylinder switch groove                          |
| Outputs                    | PNP or NPN, normally open                                     |
| Voltage range              | 5-30 V DC   |
| Voltage drop               | 1.5 V max   |
| Switching current          | 50 mA max   |
| Switch rating              | 1.5 W max   |
| Leakage current            | 0.01 mA max   |
| Internal consumption       | 10 mA max (NPN)<br>12 mA max (PNP)                            |
| On/off switching frequency | 1000 Hz max   |
| Encapsulation              | IP 67 (NEMA 6)  |
| Temperature range          | -10°C to +70°C  |
| Indication                 | LED Red (NPN)<br>LED Green (PNP)                              |
| Cable                      | Polyurethane  |

### Reed sensors

Reed type sensors are based on proven reed switch technology and provide reliable function in many applications. Simple installation and the available AC voltage range are advantages for this range of sensors.

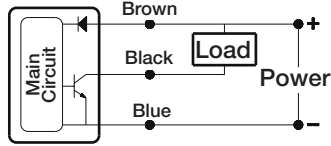
#### Technical data

|                   |                                      |
|-------------------|--------------------------------------|
| Design            | Reed element                         |
| Installation      | Mounts within cylinder switch groove |
| Outputs           | Normally open                        |
| Voltage range     | 5-120 V DC/AC                        |
| Voltage drop      | 2.5 V max                            |
| Switching current | 100 mA max                           |
| Switch rating     | 10 W max                             |
| Encapsulation     | IP 67 (NEMA 6)                       |
| Temperature range | -10°C to +70°C                       |
| Indication        | LED Red                              |
| Cable             | Polyurethane                         |

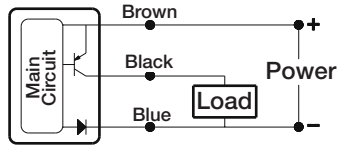
**Electronic sensors**

**Schematic**

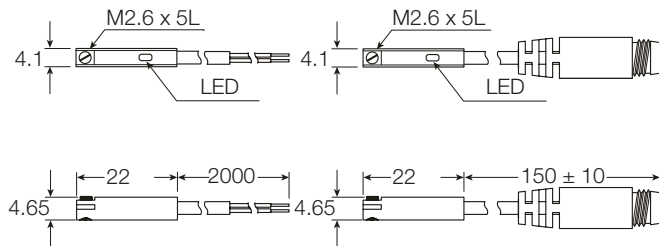
**NPN type**



**PNP type**



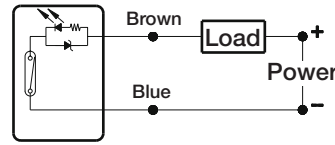
**Dimensions**



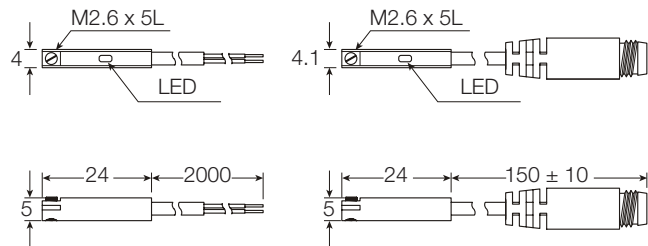
**Reed sensors**

**Schematic**

**Reed type**

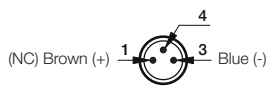


**Dimensions**

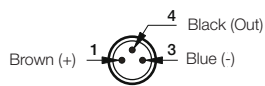


**M8 Quick Connector**

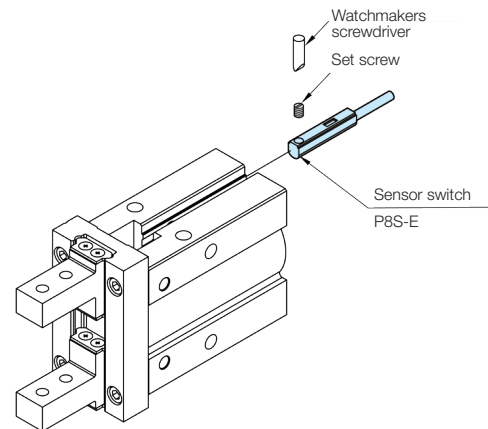
**2 wire**



**3 wire**



**Installation of Sensor**

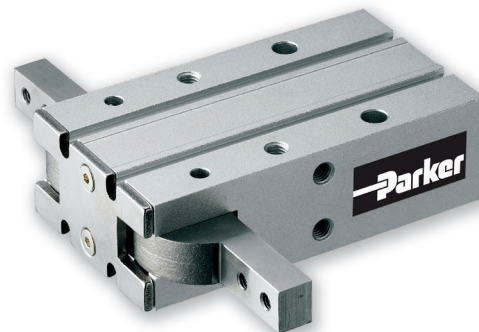


**Electronic and Reed Sensors**

| Size                     | Description                               | Order code       |
|--------------------------|---|------------------|
| <b>Flush Mount Style</b> |   |                  |
| PNP Type, normally open  | 0.165 m cable and M8 screw male connector | <b>P8S-EPSUS</b> |
| PNP Type, normally open  | 2 m PUR cable without connector           | <b>P8S-EPFXS</b> |
| NPN Type, normally open  | 0.165 m cable and M8 screw male connector | <b>P8S-ENSUS</b> |
| NPN Type, normally open  | 2 m PUR cable without connector           | <b>P8S-ENFXS</b> |
| Reed Type, normally open | 0.15 m cable and M8 screw male connector  | <b>P8S-ERSUS</b> |
| Reed Type, normally open | 2 m PUR cable without connector           | <b>P8S-ERFXS</b> |

### P5GL - 180° Angular double acting, cam style, square jaw carriers

The P5GL is a 180° angular gripper of compact size and lightweight construction. With double acting movement high gripping forces are achieved via internal cams. The anodised body has mounting points on four sides and sensors can be fitted in any of the four integral grooves.



- Bore sizes Ø10, 16, 20 and 25mm
- Double acting
- Anodised corrosion protection
- Magnetic piston as standard
- Optional sensors

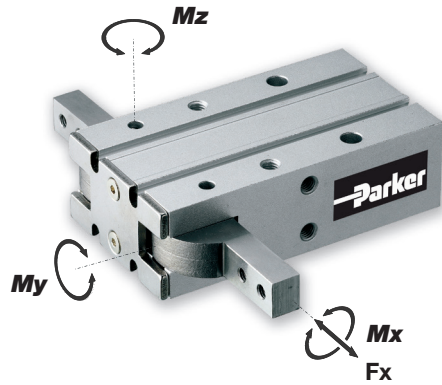
### General technical data

| Size                                       | 10                                  | 16   | 20    | 25   |
|--|-------------------------------------|------|-------|------|
| Total operating angle (°)                  | -3° to +180°                        |      |       |      |
| Total Force* (N) - Closed side             | 11                                  | 36   | 73.00 | 152  |
| Total Force* (N) - Open side               | -                                   |      |       |      |
| Total Torque* (Nm) - Closed side           | 0.32                                | 1.08 | 2.20  | 4.56 |
| Total Torque* (Nm) - Open side             | -                                   |      |       |      |
| Ø Piston bore (mm)                         | 10                                  | 16   | 20    | 25   |
| Ø Port size (mm)                           | M5                                  |      |       |      |
| Air consumption (cm <sup>3</sup> cycle) ** | 2                                   | 7    | 14    | 28   |
| Repeatability (mm)                         | ± 0.02                              |      |       |      |
| Max. work frequency (Hz)                   | 1                                   |      |       |      |
| Min. closing time (s)                      | 0.1                                 | 0.1  | 0.15  | 0.15 |
| Weight (g)                                 | 80                                  | 150  | 320   | 600  |
| Max. jaw length (mm)                       | 60                                  | 70   | 80    | 90   |
| Max. temperature (°C)                      | -10° to +60°                        |      |       |      |
| Pressure (bar)                             | 1 to 6                              |      |       |      |
| Operation                                  | Dry air, lubricated or unlubricated |      |       |      |

\* At 5 bar, L=30mm.

\*\* Cycle = opening + closing (without jaws)

**P5GL - Permissible force and torques on each jaw carrier**



**Static**

| Size | 10    | 16   | 20   | 25   |
|------|-------|------|------|------|
| Fx   | 35N   | 60N  | 100N | 140N |
| Mx   | 0,5Nm | 2 Nm | 4 Nm | 7 Nm |
| My   | 0,5Nm | 2 Nm | 4 Nm | 7 Nm |
| Mz   | 0,5Nm | 1 Nm | 2 Nm | 7 Nm |

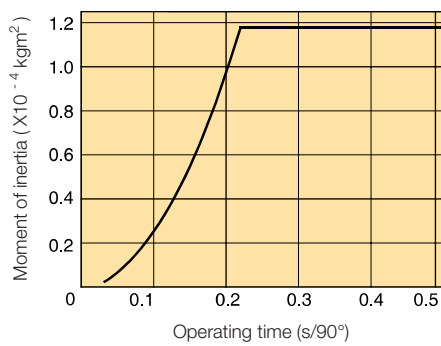
Mz at 5 bar.

Recommendation is to use flow control to limit the speed of opening to reduce impact at the end of the stroke.

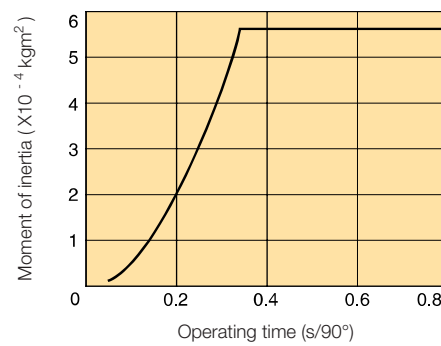
**Dynamic**

**Inertia of one of the 2 jaws (kgcm<sup>2</sup>) closing or opening time (s) :**

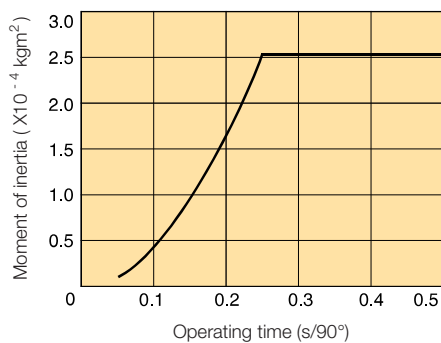
**P5GL-010MSG180B**



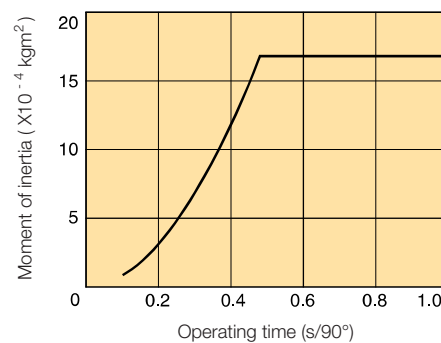
**P5GL-020MSG180B**



**P5GL-016MSG180B**



**P5GL-025MSG180B**



For a inertia of one of the 2 jaws of 0,22 kgcm<sup>2</sup>, the opening or closing time of the gripper is 0,15 s for a **size 10**.

These indications must not be exceeded if:

- any extra forces are exerted on the workpiece or on the jaws, in addition to the force or to the clamping torque.
- handling forces (acceleration, shocks, ...) must also be added.

These values are cumulative if the forces act in different directions at the same time.

**Effective holding force**

**Indication of effective holding force**

1. Although the condition differs according to the coefficient of friction between the attachment and work, select a model that can produce a holding force of 10 to 20 times the work.
2. Further allowance should be provided when great acceleration or impact is expected during work transfer.

**EX.)**

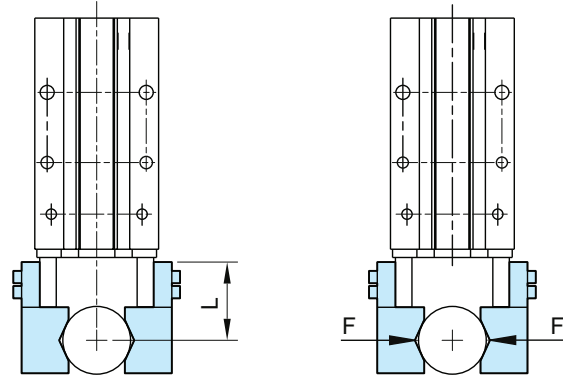
For setting the holding force to be at least 20 times the work weight;  
 Required holding force =  $0.05\text{kg} \times 20 \times 9.8\text{m/s}^2 = 10\text{N min.}$

When P5GL-016MSG180B is selected, the holding force is determined to be 17N according to the holding point distance (L = 30mm) and the pressure (5kgf/cm<sup>2</sup>).

3. The holding force shown in the table represents the holding force of one finger when all fingers and attachments are in contact with the work.

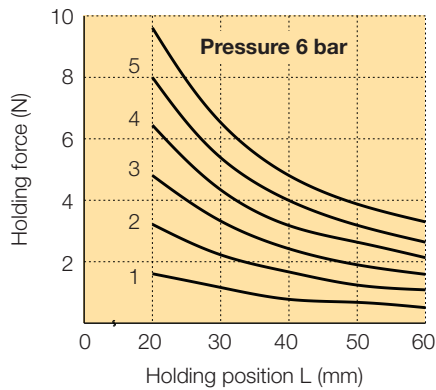
**L:** Holding point distance

**F:** Thrust of one finger

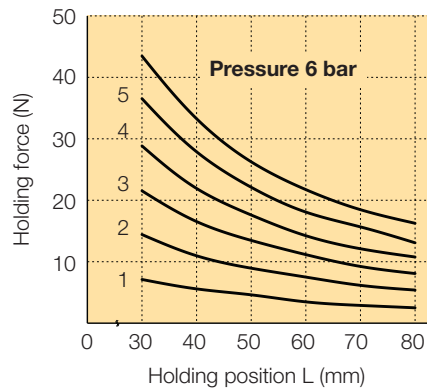


**External hold**

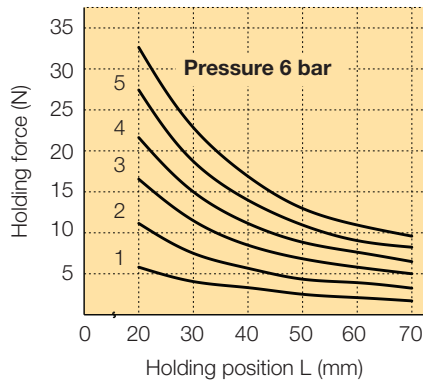
**P5GL-010MSG180B**



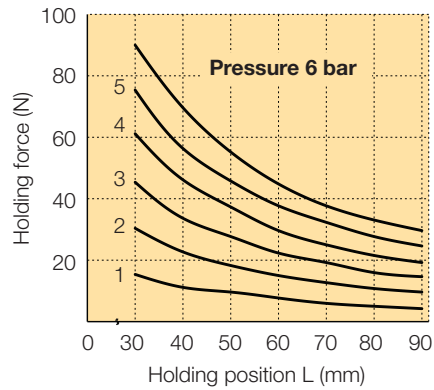
**P5GL-020MSG180B**



**P5GL-016MSG180B**

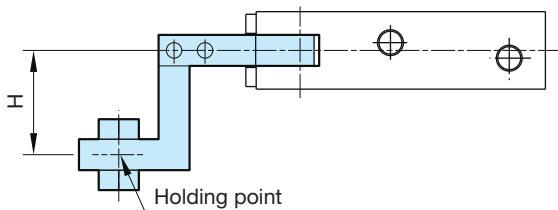


**P5GL-025MSG180B**

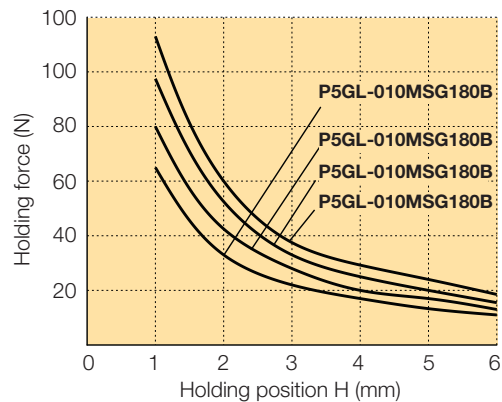


**Confirmation of holding point**

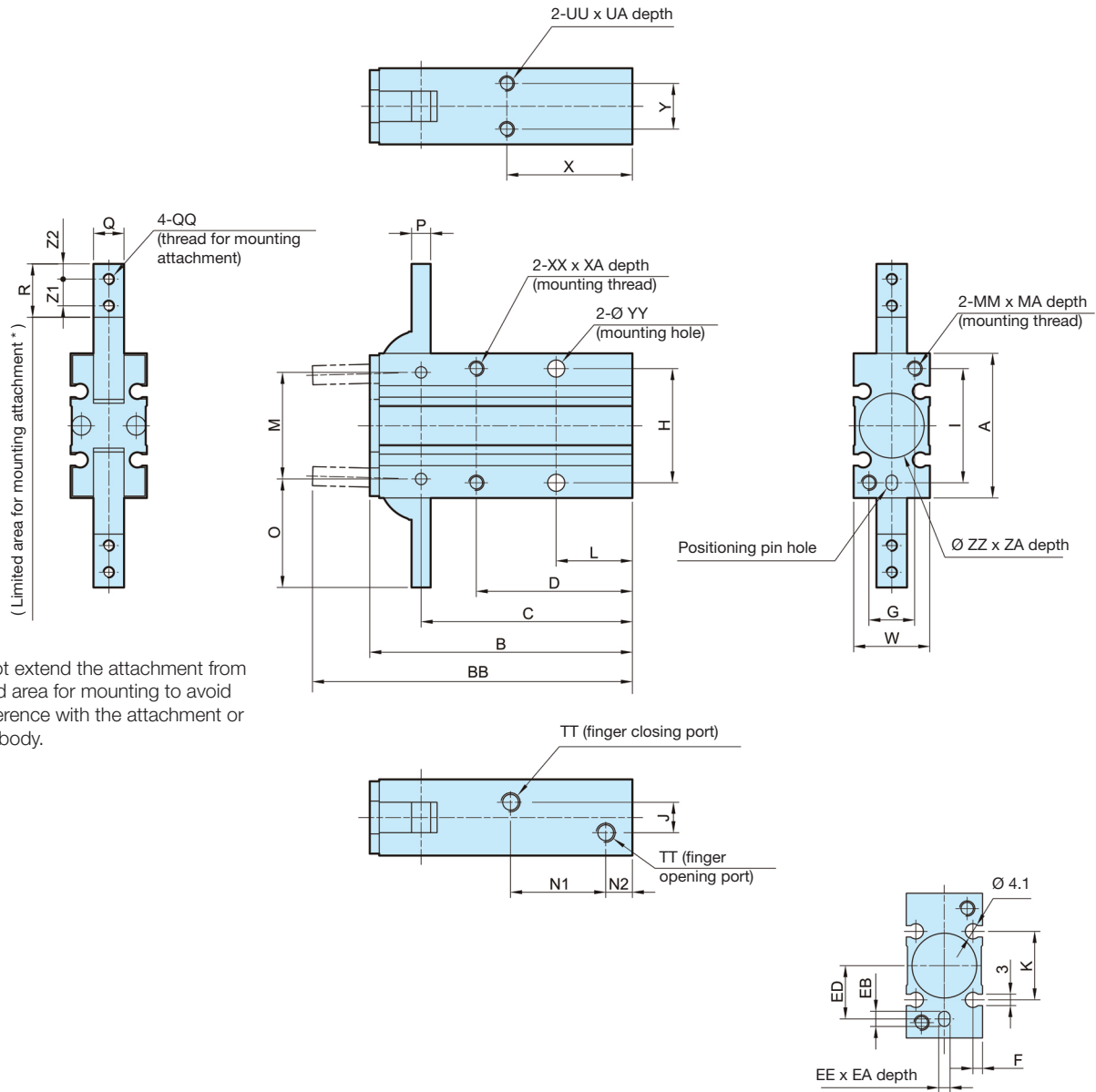
Work should be held at a point within the tange of overhanging distance (H) for a given pressure indicated in the tables. When the work is held at a point outside of the recommended range for a given pressure, it may cause adverse effect on the product life.



**P5GL**



**Dimensions (mm)**



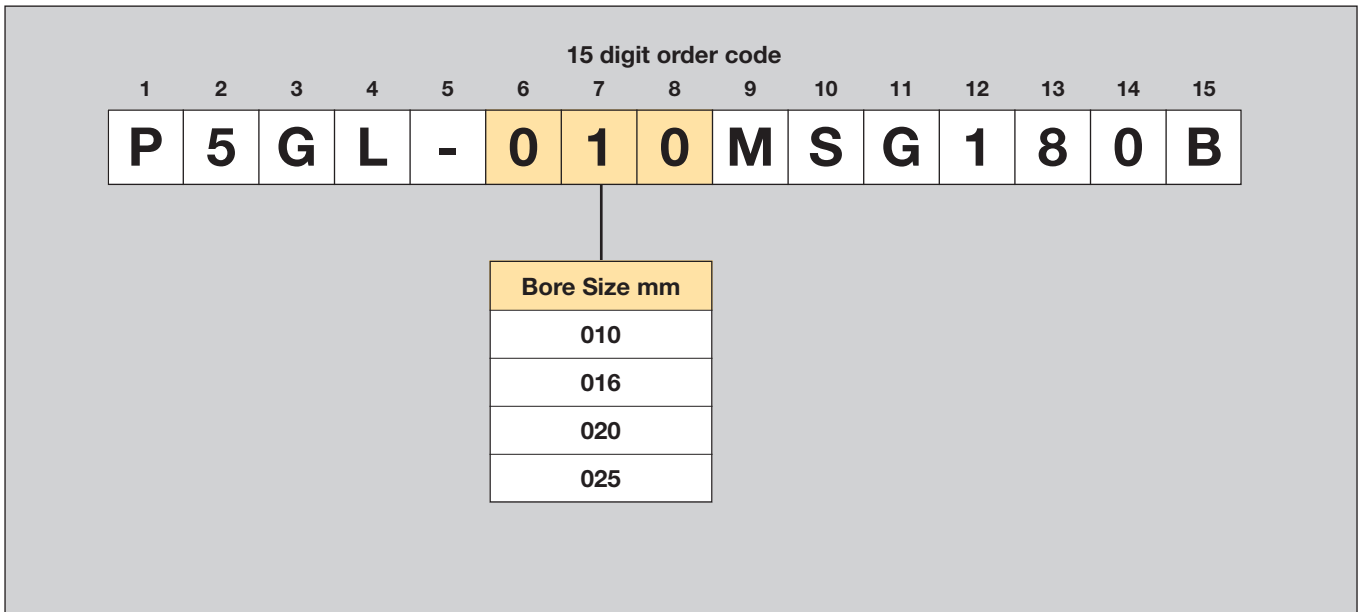
\* Do not extend the attachment from limited area for mounting to avoid interference with the attachment or main body.

| Bore mm | A  | B   | BB  | C    | D  | EE                                  | EA | EB | ED | F   | G  | H  | I  | J  | K  | L  | M  | MA | MM       | N1 | N2 | O    | P  | Q                                      |
|---------|----|-----|-----|------|----|-------------------------------------|----|----|----|-----|----|----|----|----|----|----|----|----|----------|----|----|------|----|--|
| 10      | 30 | 58  | 71  | 47,5 | 35 | 3H9 <sup>+0.025</sup> <sub>-0</sub> | 3  | 4  | 9  | 2   | 9  | 24 | 24 | 3  | 13 | 18 | 22 | 6  | M3 x 0.5 | 23 | 7  | 23,5 | 4  | 6 <sup>+0.005</sup> <sub>-0.025</sub>  |
| 16      | 38 | 69  | 84  | 55,5 | 41 | 3H9 <sup>+0.025</sup> <sub>-0</sub> | 3  | 4  | 15 | 2,5 | 12 | 30 | 30 | 8  | 18 | 20 | 28 | 8  | M4 x 0.7 | 25 | 7  | 28,5 | 5  | 8 <sup>+0.005</sup> <sub>-0.025</sub>  |
| 20      | 48 | 86  | 106 | 69   | 50 | 4H9 <sup>+0.030</sup> <sub>-0</sub> | 4  | 5  | 19 | 3   | 16 | 36 | 38 | 12 | 20 | 25 | 36 | 10 | M5 x 0.8 | 32 | 8  | 37   | 8  | 10 <sup>+0.005</sup> <sub>-0.025</sub> |
| 25      | 58 | 107 | 131 | 86   | 60 | 4H9 <sup>+0.030</sup> <sub>-0</sub> | 4  | 5  | 23 | 3   | 18 | 42 | 46 | 14 | 24 | 30 | 45 | 12 | M6 x 1   | 42 | 8  | 45   | 10 | 12 <sup>+0.005</sup> <sub>-0.025</sub> |

| Bore mm | QH  | QQ       | R    | TT                 | UA | UU       | W  | X  | XA | XX       | Y  | YY  | ZA  | ZZ                                   | Z1 | Z2 |
|---------|-----|----------|------|--------------------|----|----------|----|----|----|----------|----|-----|-----|--------------------------------------|----|----|
| 10      | 3,4 | M3 x 0.5 | 12   | M5 x 0.8 x 5 depth | 4  | M3 x 0.5 | 15 | 30 | 6  | M3 x 0.5 | 9  | 3,4 | 1,5 | 11H9 <sup>+0.043</sup> <sub>-0</sub> | 6  | 3  |
| 16      | 3,4 | M3 x 0.5 | 14   | M5 x 0.8 x 5 depth | 5  | M4 x 0.7 | 20 | 33 | 8  | M4 x 0.7 | 12 | 4,5 | 1,5 | 17H9 <sup>+0.043</sup> <sub>-0</sub> | 7  | 4  |
| 20      | 4,5 | M4 x 0.7 | 18   | M5 x 0.8 x 5 depth | 8  | M5 x 0.8 | 26 | 42 | 10 | M5 x 0.8 | 14 | 5,5 | 1,5 | 21H9 <sup>+0.052</sup> <sub>-0</sub> | 9  | 5  |
| 25      | 5,5 | M5 x 0.8 | 22,5 | M5 x 0.8 x 5 depth | 10 | M6 x 1   | 30 | 50 | 12 | M6 x 1   | 16 | 6,6 | 1,5 | 26H9 <sup>+0.052</sup> <sub>-0</sub> | 12 | 6  |

**Order Key Code**



**Note :** All grippers are supplied magnetic for optional sensing

**P5GL - 180° Angular Grippers**

| Bore mm | Order code             |
|---------|------------------------|
| 10      | <b>P5GL-010MSG180B</b> |
| 16      | <b>P5GL-016MSG180B</b> |
| 20      | <b>P5GL-020MSG180B</b> |
| 25      | <b>P5GL-025MSG180B</b> |

**Reed sensors**

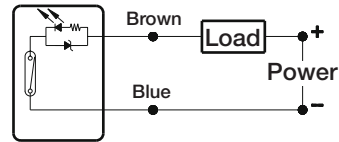
Reed type sensors are based on proven reed switch technology and provide reliable function in many applications. Simple installation and the available AC voltage range are advantages for this range of sensors.

**Technical data**

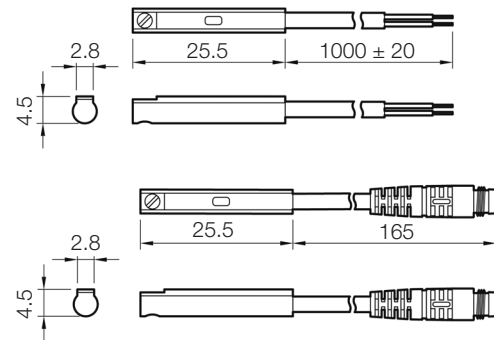
|                   |                                      |
|-------------------|--------------------------------------|
| Design            | Reed element                         |
| Installation      | Mounts within cylinder switch groove |
| Outputs           | Normally open                        |
| Voltage range     | 5-120 V DC/AC                        |
| Voltage drop      | 2.5 V max                            |
| Switching current | 100 mA max                           |
| Switch rating     | 10 W max                             |
| Encapsulation     | IP 67 (NEMA 6)                       |
| Temperature range | -10°C to +70°C                       |
| Indication        | LED Red                              |
| Cable             | Polyurethane                         |

**Schematic**

**Reed type**

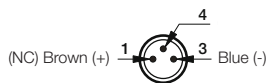


**Dimensions**

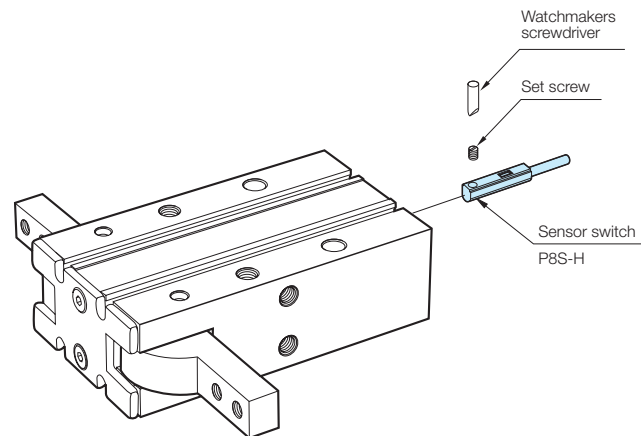


**M8 Quick Connector**

**2 wire QC wiring**



**Installation of Sensor**



**Reed Sensors**

| Size                     | Description                                  | Order code       |
|--------------------------|--|------------------|
| <b>Flush Mount Style</b> |  |                  |
| Reed Type, normally open | 0.15 m PUR cable and M8 screw male connector | <b>P8S-HRSUS</b> |
| Reed Type, normally open | 1 m PUR cable without connector              | <b>P8S-HRFCs</b> |

### Connecting cables with one connector

The cables have an integral snap-in female connector.



| Type of cable   | Cable/connector              | Weight<br>kg | Order code        |
|---|------------------------------|--------------|-------------------|
| <b>Cables for sensors, complete with one female connector</b> |                              |              |                   |
| Cable, Flex PVC   | 3 m, 8 mm Snap-in connector  | 0,07         | <b>9126344341</b> |
| Cable, Flex PVC   | 10 m, 8 mm Snap-in connector | 0,21         | <b>9126344342</b> |
| Cable, Super Flex PVC   | 3 m, 8 mm Snap-in connector  | 0,07         | <b>9126344343</b> |
| Cable, Super Flex PVC   | 10 m, 8 mm Snap-in connector | 0,21         | <b>9126344344</b> |
| Cable, Polyurethane   | 3 m, 8 mm Snap-in connector  | 0,01         | <b>9126344345</b> |
| Cable, Polyurethane   | 10 m, 8 mm Snap-in connector | 0,20         | <b>9126344346</b> |

### Male connectors for connecting cables

Cable connectors for producing your own connecting cables. The connectors can be quickly attached to the cable without special tools. Only the outer sheath of the cable is removed. The connectors are available for M8 and M12 screw connectors and meet protection class IP 65.



| Connector           | Weight<br>kg | Order code        |
|---------------------|--------------|-------------------|
| M8 screw connector  | 0,017        | <b>P8SCS0803J</b> |
| M12 screw connector | 0,022        | <b>P8SCS1204J</b> |

### Ready to use connecting cables with connectors at each end

As accessories the system comprises a large number of different cables in order to meet all requirements that may arise and to make the installation simple, fast and reliable.

Cables with moulded 8 mm snap-in round contacts in both ends. The cables are available in two types, one with a straight male and female connectors respectively, and one with a straight 3-pole male connector in one end and an angled 3-pole female connector in the other end.



#### Technical data

##### Contacts

Moulded 8 mm snap-in male/female contacts.

Enclosure IP67

##### Cable

Conductor 3x0,25 mm<sup>2</sup> (32x0,10 mm<sup>2</sup>)

Sheath PVC/PUR

Colour Black

## Installation and Maintenance for P5GA, P5GB, P5GD and P5GL Grippers



Disconnect air and electrical supplies before attempting repair or maintenance.  
 See ISO 4414-1982 for safety requirements covering the installation and use of pneumatic equipment.

### Selection

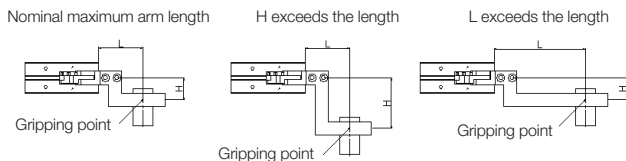
- 1 Do not apply a load over the operating limit range.**  
 Select the model considering max. allowable load and allowable moment. When the grippers are used outside of the normal operating limits, excessive loads can cause wear that can lead to malfunction, shorter life expectancy and safety concerns.
- 2 Do not apply excessive forces and impacts.**  
 This may cause problems and possible failure.

### Mounting

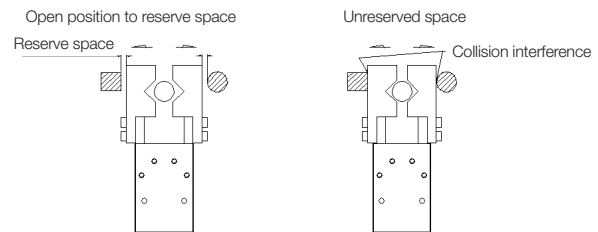
1. Use air as media. When piping, make sure the pipeline is completely cleaned to maintain the cleanness of the air.
2. Install an air filter in the gripper pipeline to eliminate / reduce moisture and replace the filter element periodically.
3. Avoid using the gripper in moist, oily or dusty environments.
4. When installing the gripper, tighten the fix screw according to normal specified torque standard.
5. When the gripper is operating do not put your hands on/near the grippers to prevent injuries.
6. To prevent gripper malfunction or injuries please do not exceed the capacity range of gripper when operating.
7. When installing and operating the gripper, avoid vibration and instant impact caused by any external force.
8. Apply lithium lubricant to the slide track of the gripper to prevent rust and extend the gripper life cycle.

### Operation

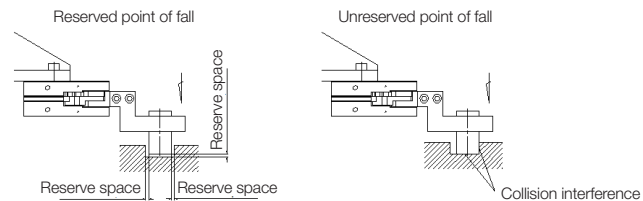
1. When designing the operation path for the gripper, well planned path and reserve extra space is suggested to prevent impact occur. External impact could endanger the safety of the operator and cause damage to the equipment.
2. When designing the finger blanks, the strength of material should be able to bear the weight of the workpiece. Finger blanks should be lightweight. Over size/weight could affect the grippers ability to function normally.
3. Please take note of the 'maximum arm length' specified in the catalogue. Finger blanks exceeding the specified length will cause the gripping force to drop rapidly.
7. The gripping contact area should be reduced when the finger blanks are designed for gripping small / thinner workpiece. Holding small / thinner workpiece with large contact areas will cause the workpiece to shift / loosen easily.
8. Notice the position when installing the gripper. You should avoid lateral impact to the gripper when the fingers are at the opening position. This may cause the fingers to break easily.



4. The bore size of the gripper should correspond to the size/weight of the workpiece. Several grippers can be used to grip large/heavy work piece. Overloading the gripper cylinder is strictly prohibited.
5. Avoid allowing the fingers to sustain lateral force and torque force. This may cause the fingers to loosen resulting in excessive wear.
6. Be cautious when the power is off for periods of time or when experiencing power failure. This could cause a drop in the air pressure and cause the workpiece to fall or become loose.



9. When configuring the gripper to certain designated position and unloading the workpiece, clearance must be reserved at the point of fall to avoid direct collision interference.



### Environment

- 1 Do not use in atmosphere where the gripper contacts directly with liquid such as cutting oil.**  
 Conditions where the gripper is exposed directly to cutting oil, coolant and oil mist may lead to vibration, increase of moving part resistance, air leakage, etc.
- 2 Do not use in atmosphere where the gripper contacts directly with material such as powder dust, dust, spatter etc.**
- 3 Do not use in direct sun light.**
- 4 Do not use in environment where there is heat source.**  
 Use a cover when there is a heat source around the gripper, or if temperature of product increases and exceeds operating temperature range by emissive heat.
- 5 Do not subject it to excessive vibration and/or impact.**  
 This results in damage and/or malfunction.  
 Contact Parker if the gripper is used in the above conditions.

# Specifying air quality (purity) in accordance with ISO8573-1:2010, the international standard for Compressed Air Quality

ISO8573-1 is the primary document used from the ISO8573 series as it is this document which specifies the amount of contamination allowed in each cubic metre of compressed air.

ISO8573-1 lists the main contaminants as Solid Particulate, Water and Oil. The purity levels for each contaminant are shown separately in tabular form, however for ease of use, this document combines all three contaminants into one easy to use table.

| ISO8573-1:2010 CLASS | Solid Particulate  |                |              |                                      | Water                    |                         | Oil   |
|----------------------|--|----------------|--------------|--------------------------------------|--------------------------|-------------------------|---|
|                      | Maximum number of particles per m <sup>3</sup>                                 |                |              | Mass Concentration mg/m <sup>3</sup> | Vapour Pressure Dewpoint | Liquid g/m <sup>3</sup> | Total Oil (aerosol liquid and vapour) mg/m <sup>3</sup> |
|                      | 0,1 - 0,5 micron   | 0,5 - 1 micron | 1 - 5 micron |                                      |                          |                         |   |
| 0                    | As specified by the equipment user or supplier and more stringent than Class 1 |                |              |                                      |                          |                         |   |
| 1                    | ≤ 20 000   | ≤ 400          | ≤ 10         | -                                    | ≤ -70 °C                 | -                       | 0,01  |
| 2                    | ≤ 400 000  | ≤ 6 000        | ≤ 100        | -                                    | ≤ -40 °C                 | -                       | 0,1   |
| 3                    | -  | ≤ 90 000       | ≤ 1 000      | -                                    | ≤ -20 °C                 | -                       | 1   |
| 4                    | -  | -              | ≤ 10 000     | -                                    | ≤ +3 °C                  | -                       | 5   |
| 5                    | -  | -              | ≤ 100 000    | -                                    | ≤ +7 °C                  | -                       | -   |
| 6                    | -  | -              | -            | ≤ 5                                  | ≤ +10 °C                 | -                       | -   |
| 7                    | -  | -              | -            | 5 - 10                               | -                        | ≤ 0,5                   | -   |
| 8                    | -  | -              | -            | -                                    | -                        | 0,5 - 5                 | -   |
| 9                    | -  | -              | -            | -                                    | -                        | 5 - 10                  | -   |
| X                    | -  | -              | -            | > 10                                 | -                        | > 10                    | > 10  |

## Specifying air purity in accordance with ISO8573-1:2010

When specifying the purity of air required, the standard must always be referenced, followed by the purity class selected for each contaminant (a different purity class can be selected for each contamination if required).

An example of how to write an air quality specification is shown below:

### ISO 8573-1:2010 Class 1.2.1

ISO 8573-1:2010 refers to the standard document and its revision, the three digits refer to the purity classifications selected for solid particulate, water and total oil. Selecting an air purity class of 1.2.1 would specify the following air quality when operating at the standard's reference conditions :

#### Class 1 - Particulate

In each cubic metre of compressed air, the particulate count should not exceed 20,000 particles in the 0.1 - 0.5 micron size range, 400 particles in the 0.5 - 1 micron size range and 10 particles in the 1 - 5 micron size range.

#### Class 2 - Water

A pressure dewpoint (PDP) of -40°C or better is required and no liquid water is allowed.

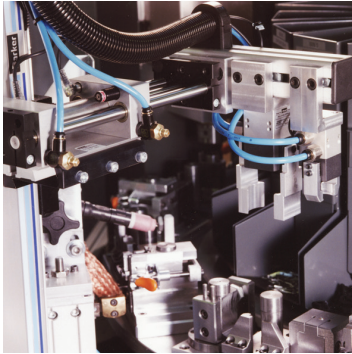
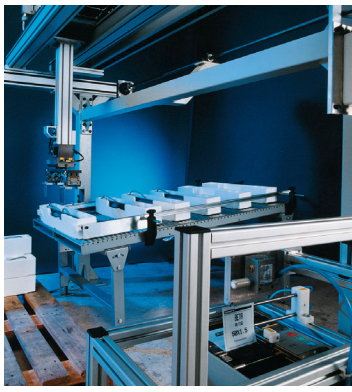
#### Class 1 - Oil

In each cubic metre of compressed air, not more than 0.01mg of oil is allowed. This is a total level for liquid oil, oil aerosol and oil vapour.

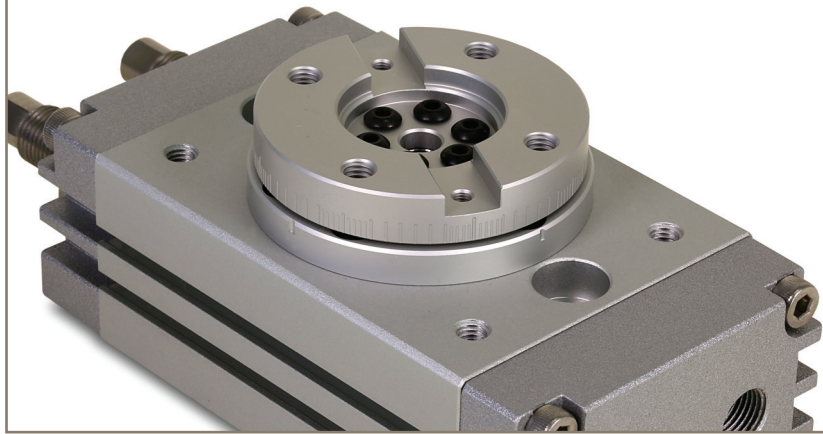
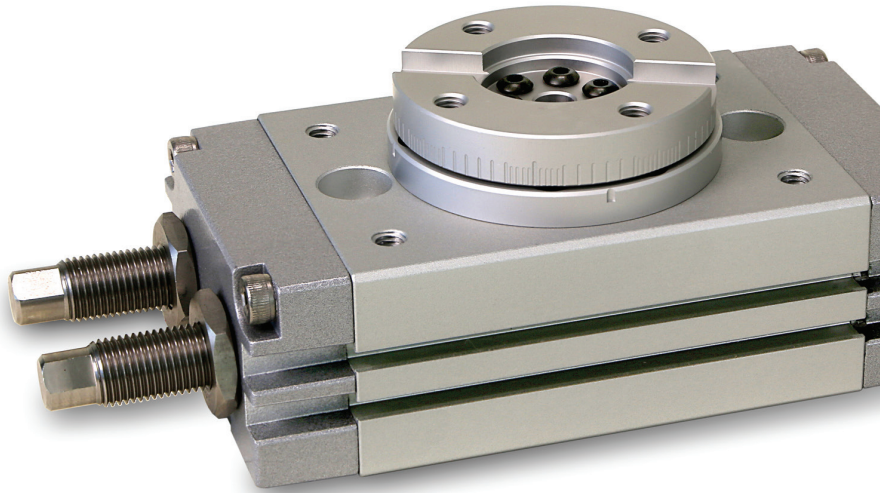
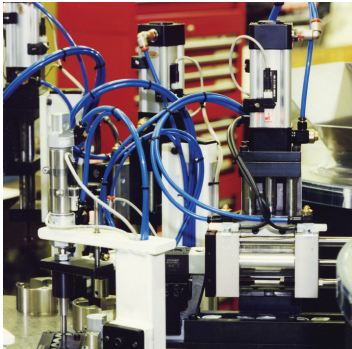
## ISO8573-1:2010 Class zero

- **Class 0 does not mean zero contamination.**
- **Class 0 requires the user and the equipment manufacturer to agree contamination levels as part of a written specification.**
- **The agreed contamination levels for a Class 0 specification should be within the measurement capabilities of the test equipment and test methods shown in ISO8573 Pt 2 to Pt 9.**
- **The agreed Class 0 specification must be written on all documentation to be in accordance with the standard.**
- **Stating Class 0 without the agreed specification is meaningless and not in accordance with the standard.**
- **A number of compressor manufacturers claim that the delivered air from their oil-free compressors is in compliance with Class 0.**
- **If the compressor was tested in clean room conditions, the contamination detected at the outlet will be minimal. Should the same compressor now be installed in typical urban environment, the level of contamination will be dependent upon what is drawn into the compressor intake, rendering the Class 0 claim invalid.**
- **A compressor delivering air to Class 0 will still require purification equipment in both the compressor room and at the point of use for the Class 0 purity to be maintained at the application.**
- **Air for critical applications such as breathing, medical, food, etc typically only requires air quality to Class 2.2.1 or Class 2.1.1.**
- **Purification of air to meet a Class 0 specification is only cost effective if carried out at the point of use.**



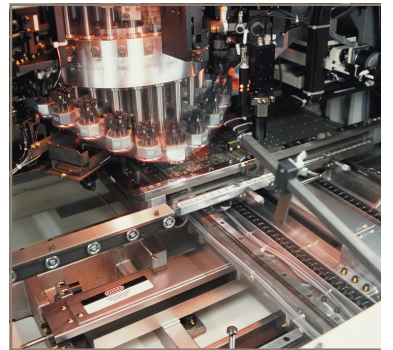


aerospace  
climate control  
electromechanical  
filtration  
fluid & gas handling  
hydraulics  
**pneumatics**  
process control  
sealing & shielding




# Rotary Tables P5RS Series

Sizes 16, 20, 25 and 32 mm




ENGINEERING YOUR SUCCESS.

| <b>Contents</b>                                 | <b>page</b> |
|---|-------------|
| P5RS Rotary Tables General Technical Data ..... | 49          |
| Features .....                                  | 50-51       |
| Operating and Environmental Data .....          | 52          |
| Material Specification .....                    | 52          |
| Selecting a Pneumatic Rotary Table .....        | 53          |
| Model Selection .....                           | 53          |
| Load Type .....                                 | 54          |
| Calculating the Moment of Inertia .....         | 55          |
| Dimensions .....                                | 56          |
| Order Key Code .....                            | 57          |
| Reed Sensors .....                              | 58          |
| Installation and Maintenance .....              | 60          |




**Important**

Before attempting any external or internal work on the cylinder or any connected components, make sure the cylinder is vented and disconnect the air supply in order to ensure isolation of the air supply.



**Note**

All technical data in this catalogue are typical data only.  
 Air quality is essential for maximum cylinder service life (see ISO 8573).

 **WARNING**

**FAILURE OR IMPROPER SELECTION OR IMPROPER USE OF THE PRODUCTS AND/OR SYSTEMS DESCRIBED HEREIN OR RELATED ITEMS CAN CAUSE DEATH, PERSONAL INJURY AND PROPERTY DAMAGE.**

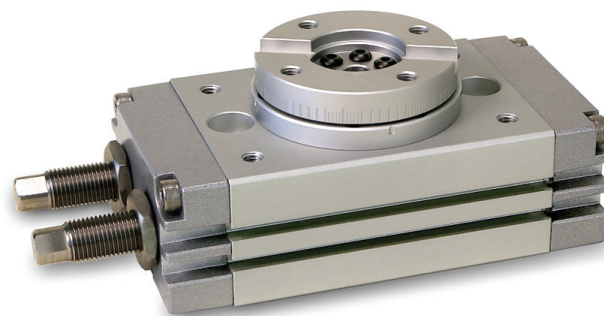
This document and other information from Parker Hannifin Corporation, its subsidiaries and authorized distributors provide product and/or system options for further investigation by users having technical expertise. It is important that you analyze all aspects of your application and review the information concerning the product or system in the current product catalog. Due to the variety of operating conditions and applications for these products or systems, the user, through its own analysis and testing, is solely responsible for making the final selection of the products and systems and assuring that all performance, safety and warning requirements of the application are met. The products described herein, including without limitation, product features, specifications, designs, availability and pricing, are subject to change by Parker Hannifin Corporation and its subsidiaries at any time without notice.

**SALE CONDITIONS**

The items described in this document are available for sale by Parker Hannifin Corporation, its subsidiaries or its authorized distributors. Any sale contract entered into by Parker will be governed by the provisions stated in Parker's standard terms and conditions of sale (copy available upon request).

## P5RS - Rotary Actuators

The P5RS rotary table units provide precise control even under heavy loads, with specially designed load fixing and centring capabilities. End stroke cushioning using an adjusting bolt or optional shock absorber offers dependable linear cushioning enabling objects to be carried and positioned safely and securely.



- Bores Ø16, 20, 25 and 32 mm
- Twin rack and pinion
- Adjustable between 0° and 190°
- Magnetic piston standard
- Stroke adjusters standard
- Optional shock absorbers bores Ø20 and 25 mm
- Easy mounting of work piece

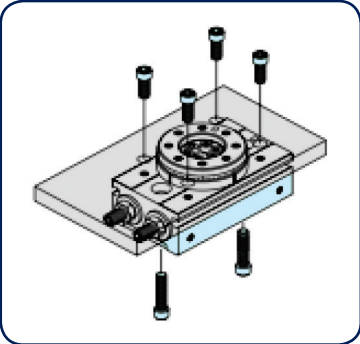
### General technical data

| Size  | 16                                  | 20        | 25        | 32        |
|---|-------------------------------------|-----------|-----------|-----------|
| Total stroke (°)                                  | 0 to 190                            |           |           |           |
| Total torque (Nm)*                                | 1.21                                | 2.51      | 4.91      | 9.86      |
| Ø Piston bore (mm)                                | 2 x 16                              | 2 x 20    | 2 x 25    | 2 x 32    |
| Ø Air port size (mm)                              | G1/8                                |           |           |           |
| Volume (cm <sup>3</sup> /190°)                    | 6.6                                 | 13.5      | 20.1      | 34.1      |
| Air consumption (cm <sup>3</sup> /90°)            | 37                                  | 77        | 114       | 194       |
| Air consumption (cm <sup>3</sup> /190°)           | 79                                  | 162       | 241       | 409       |
| Rotating time (s/90°)* elastic bumpers            | 0,2 to 1 for 90°                    |           |           |           |
| Rotating time (s/90°)* hydraulic shocks           | 0,2 to 0,7 for 90°                  |           |           |           |
| Sensing   | Magnet in                           |           |           |           |
| Max kinetic energy (mJ) elastic bumpers           | 7                                   | 40        | 81        | 320       |
| Max kinetic energy (mJ) hydraulic shocks          |                                     |           | 294       | 1600      |
| Minimum angle to not decrease energy capacity (°) | 43                                  | 40        | 81        | 320       |
| Axial load (a) pull (N)                           | 74                                  | 137       | 197       | 296       |
| Axial load (b) push (N)                           | 78                                  | 137       | 363       | 451       |
| Radial load (N)                                   | 78                                  | 147       | 196       | 314       |
| Allowable moment (Nm)                             | 2.4                                 | 4         | 5.3       | 9.7       |
| Hollow shaft diameter (mm)                        | 6                                   | 10        | 13        | 13        |
| End stroke threads size                           | M10 x 1,0                           | M12 x 1,0 | M14 x 1,5 | M20 x 1,5 |
| Weight (g) elastic bumpers                        | 700                                 | 1160      | 1570      | 3070      |
| Weight (g) hydraulic shocks                       | 700                                 | 1160      | 1570      | 3070      |
| Max. temperature (°C)                             | -5° to +60°                         |           |           |           |
| Air pressure (bar)                                | 1 to 9                              |           |           |           |
| Type of drive                                     | Twin rack inbetween 1 pinion        |           |           |           |
| Operation   | Dry air, lubricated or unlubricated |           |           |           |

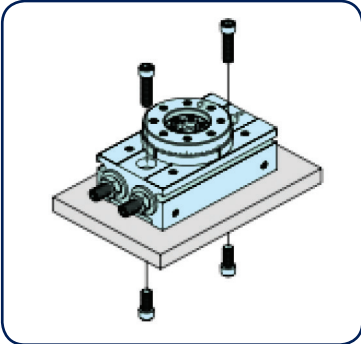
\* At 5 bar

**Flexible Installation**

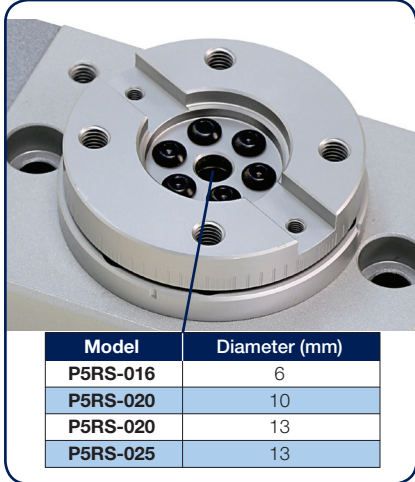
**Top Mounting**



**Bottom Mounting**



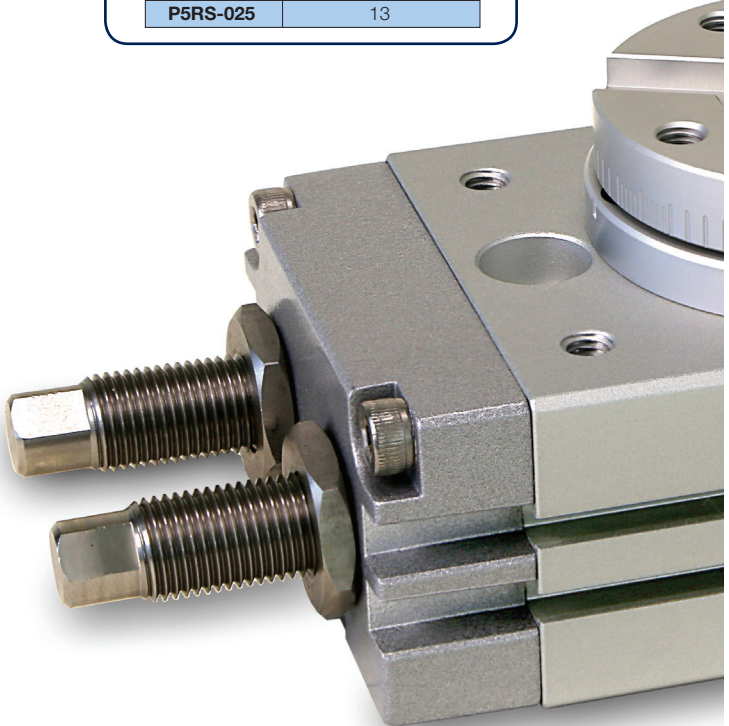
**Hollow Axis  
 to accommodate piping  
 and wiring**



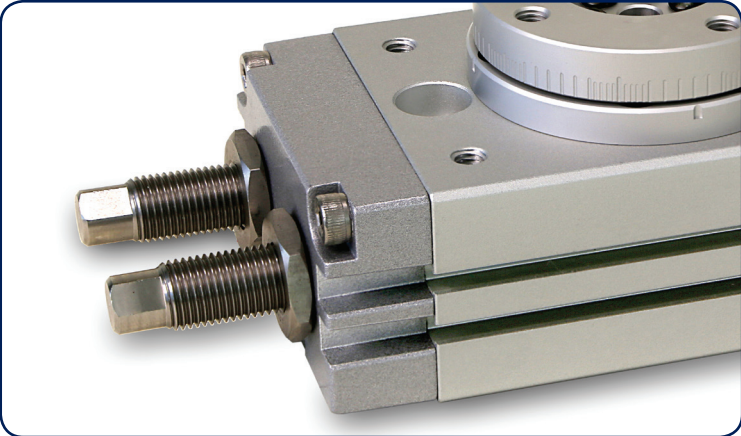
| Model    | Diameter (mm) |
|----------|---------------|
| P5RS-016 | 6             |
| P5RS-020 | 10            |
| P5RS-020 | 13            |
| P5RS-025 | 13            |

**Installation Sizes**

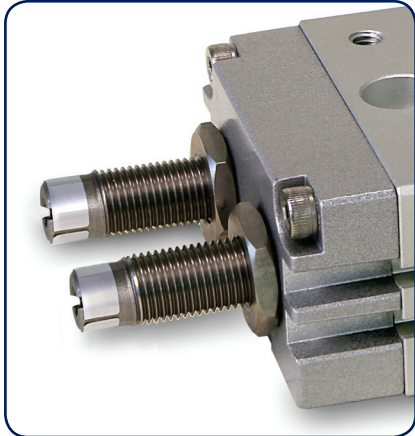
| Bore | Order code      | A (mm) | B (mm) | C (mm) | D (mm) | Weight (Kg) |
|------|-----------------|--------|--------|--------|--------|-------------|
| 16   | P5RS-016DSG190B | 108    | 58     | 47     | 33     | 0.7         |
| 20   | P5RS-020DSG190B | 128    | 68     | 55     | 38     | 1.16        |
| 25   | P5RS-020DSG190B | 135.5  | 77     | 58.5   | 41.5   | 1.57        |
| 32   | P5RS-025DSG190B | 170    | 94     | 69.5   | 49.5   | 3.07        |



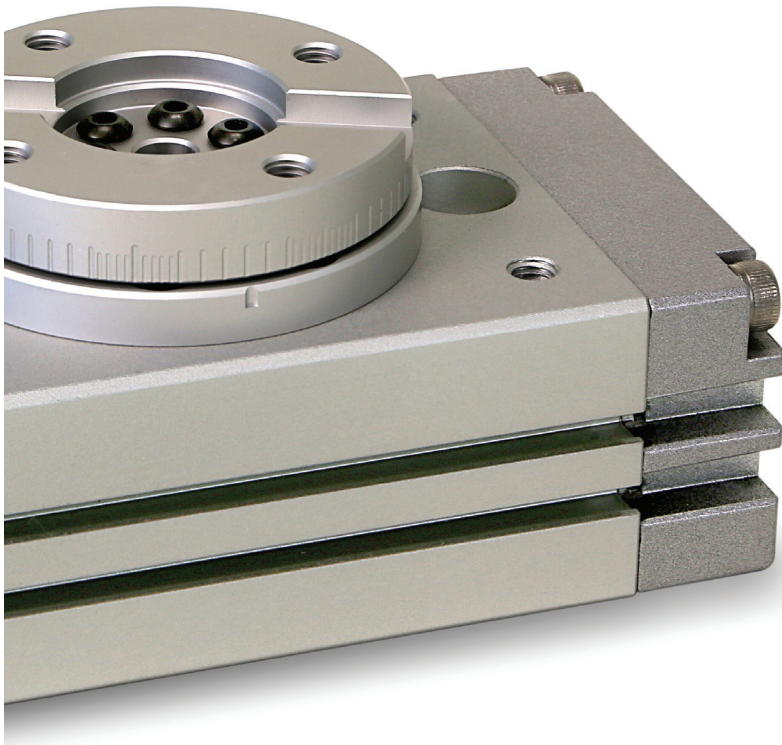
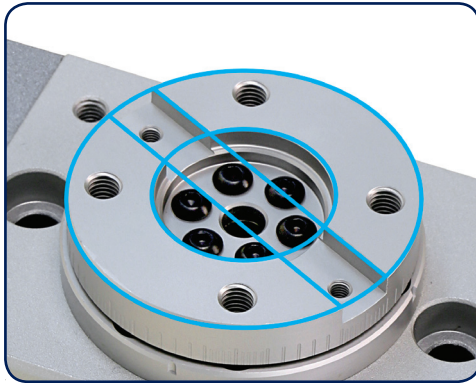
**0 to 190°  
 Rotation angle adjustment**



**Optional Shock  
 Absorbers**



**Accurate workpiece location**

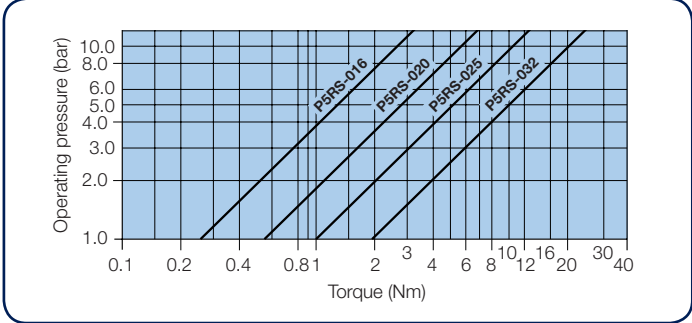


**Integrated protected sensor grooves**



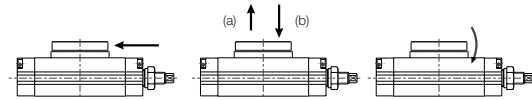
**Technical Information**

**Theoretical Torque**



**Allowable Load**

Set the load and moment to be applied to the table within the allowable values shown in the table below. (Values outside of limitations will cause excessive play, deteriorate accuracy and shorten service life).

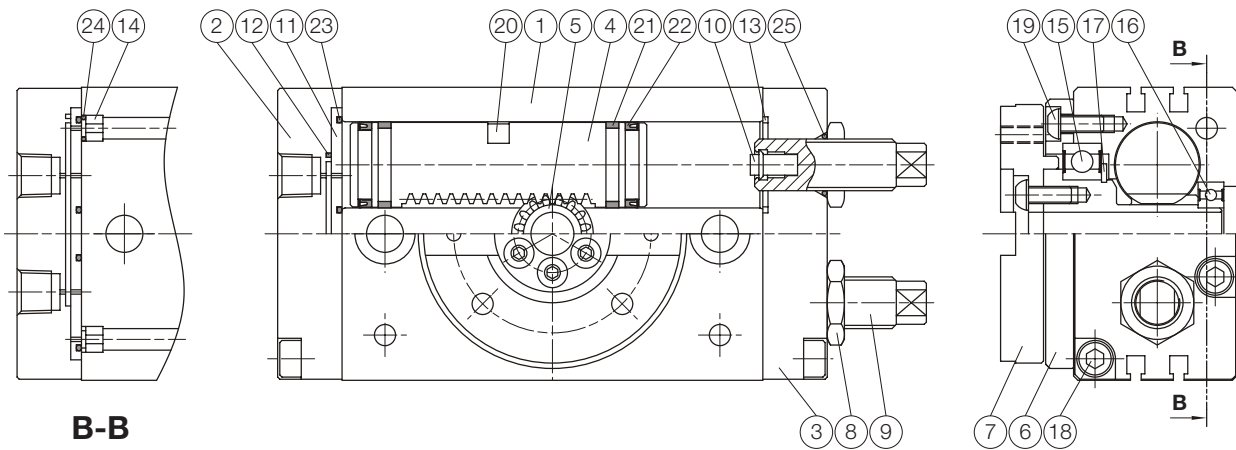


| Model    | Allowable radial load (N) | Allowable thrust load (N) |     | Allowable moment (Nm) |
|----------|---------------------------|---------------------------|-----|-----------------------|
|          |                           | (a)                       | (b) |                       |
| P5RS-016 | 78                        | 74                        | 78  | 2.4                   |
| P5RS-020 | 147                       | 137                       | 137 | 4                     |
| P5RS-020 | 196                       | 197                       | 363 | 5.3                   |
| P5RS-025 | 314                       | 296                       | 451 | 9.7                   |

**Operating and environmental data**

|                      |  |
|----------------------|--|
| Operating medium     | For best possible service life and trouble-free operation dry, filtered compressed air to ISO 8573-1:2010 quality class 3.4.3 should be used. This specifies a dew point of +3°C for indoor operation ( a lower dew point should be selected for outdoor operation) and is in line with the air quality from most standard compressors with a standard filter. |
| Operating pressure   | 1 bar to 9 bar   |
| Ambient temperature  | -5 °C to +60 °C  |
| Pre-lubricated       | Further lubrication is normally not necessary. If additional lubrication is introduced it must be continued.   |
| Corrosion resistance | Resistance to corrosion and chemicals.   |

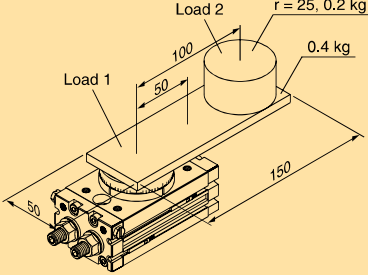
**Material specification**



| Pos | Part             | Material        |
|-----|------------------|-----------------|
| 1   | Body             | Aluminium alloy |
| 2   | Cover            | Aluminium alloy |
| 3   | End cover        | Aluminium alloy |
| 4   | Piston           | Stainless steel |
| 5   | Pinion           | SCM             |
| 6   | Bearing retainer | Aluminium alloy |
| 7   | Table            | Aluminium alloy |
| 8   | Seal nut         | Stainless steel |
| 9   | Shock absorber   | Stainless steel |
| 10  | Cushion pad      | NBR             |
| 11  | Plate            | Aluminium alloy |
| 12  | Packing          | NBR             |
| 13  | Gasket           | NBR             |

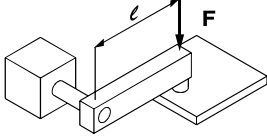
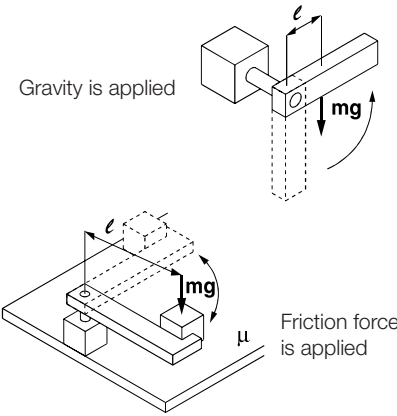
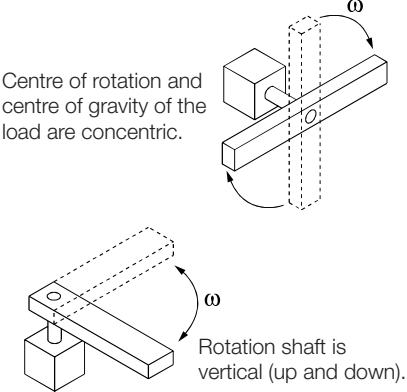
| Pos | Part           | Material        |
|-----|----------------|-----------------|
| 14  | Fixed          | Copper          |
| 15  | Ball bearing   | Bearing steel   |
| 16  | Ball bearing   | Bearing steel   |
| 17  | Snap ring      | Spring steel    |
| 18  | Screw          | SCM             |
| 19  | Screw          | SCM             |
| 20  | Magnet         | Magnet material |
| 21  | Wear ring      | PTFE            |
| 22  | Piston packing | NBR             |
| 23  | O-ring         | NBR             |
| 24  | O-ring         | NBR             |
| 25  | O-ring         | NBR             |

**Model selection**

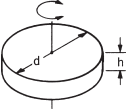
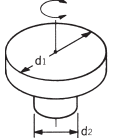
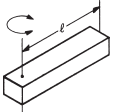
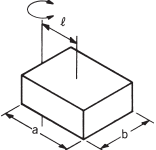
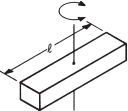
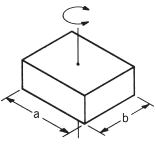
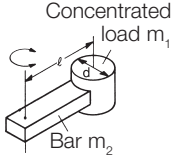
| Selection Procedure   | Remarks  | Selection Example  |
|---|--|--|
| <p><b>1</b> <b>Operating conditions</b></p> <p>Operating conditions are as follows:</p> <ul style="list-style-type: none"> <li>Provisionally selected model</li> <li>Operating pressure: MPa</li> <li>Mounting position</li> <li>Load type                             <ul style="list-style-type: none"> <li>Static load: N.m</li> <li>Resistance load: N.m</li> <li>Inertial load: N.m</li> </ul> </li> <li>Load dimensions: m</li> <li>Load mass: kg</li> <li>Rotation time: s</li> <li>Rotation angle: rad</li> </ul>     | <ul style="list-style-type: none"> <li>See page 49 for load type.</li> <li>The unit of the rotation angle is Radians.<br/> <math>180^\circ = \pi \text{ rad}</math><br/> <math>90^\circ = \pi / 2 \text{ rad}</math></li> </ul>  |  <p>Provisionally selected model: P5RS-016<br/>                     Operating pressure: 3 bar<br/>                     Mounting position: Vertical, Type of load: Inertial load<br/>                     Rotation time: 6s    Rotation angle: <math>\pi \text{ rad}</math> (<math>180^\circ</math>)</p> |
| <p><b>2</b> <b>Calculating of moment of inertia</b></p> <p>Calculate the moment of inertia of the load.</p> <p>⇒ P.55</p>   | <ul style="list-style-type: none"> <li>If the moment of inertia of the load is made up of multiple components, calculate the moment of inertia of each component and add them together.</li> </ul>   | <p>Load 1 moment of inertia: <math>I_1</math></p> $I_1 = 0.4 \times \frac{0.15^2 + 0.05^2}{12} + 0.4 \times 0.05^2 = 0.001833$ <p>Load 2 moment of inertia: <math>I_2</math></p> $I_2 = 0.2 \times \frac{0.025^2}{2} + 0.2 \times 0.1^2 = 0.002063$ <p>Total moment of inertia: <math>I</math></p> $I = I_1 + I_2 = 0.003896 \text{ [kg m}^2\text{]}$                                      |
| <p><b>3</b> <b>Calculating of necessary torque</b></p> <p>Calculate necessary torque corresponding to the load type and ensure it is within effective torque range.</p> <ul style="list-style-type: none"> <li>Static load (<math>T_s</math>)<br/>Necessary torque <math>T = T_s</math></li> <li>Resistance load (<math>T_f</math>)<br/>Necessary torque <math>T = T_f \times (3 \text{ to } 5)</math></li> <li>Inertial load (<math>T_a</math>)<br/>Necessary torque <math>T = T_a \times 10</math></li> </ul> <p>⇒ P.54</p> | <ul style="list-style-type: none"> <li>When calculating the inertial load, if the rotation time exceeds 2s per <math>90^\circ</math>, inertial load is calculated with rotation time 2s per <math>90^\circ</math>.</li> <li>Even for resistance load, when the load is rotated, necessary torque calculated from inertial load shall be added.</li> </ul> <p>Necessary torque<br/> <math>T = T_f \times (3 \text{ to } 5) + T_a \times 10</math></p> | <p>Inertial load: <math>T_a</math></p> $T_a = I \omega$ $\omega = \frac{2\Theta}{t^2} \text{ [rad/s}^2\text{]}$ <p>Necessary torque: <math>T</math></p> $T = T_a \times 10$ $= 0.003896 \times \frac{2 \times \pi}{4^2} \times 10 = 0.015 \text{ [N.m]}$ <p>(<math>t</math> is calculated with 2s per <math>90^\circ</math>)</p> <p>0.109 N.m &lt; Effective torque    OK</p>              |
| <p><b>4</b> <b>Checking rotation time</b></p> <p>Confirm that it is within the adjustable range of rotation time.</p> <p>⇒ P.49</p>   | <ul style="list-style-type: none"> <li>Converted to the time per <math>90^\circ</math> for comparison. (For example, 6s/<math>180^\circ</math> is converted to 3s/<math>90^\circ</math>).</li> </ul>   | $1.0 \leq t \leq 5$ <p><math>t = 3\text{s}/90^\circ</math> OK</p>  |
| <p><b>5</b> <b>Calculation of kinetic energy</b></p> <p>Confirm that the load's kinetic energy is within the allowable value.</p> <p>Confirm it with the graph of the moment of inertia and the rotation time.</p> <p>⇒ P.49</p>  | <ul style="list-style-type: none"> <li>If the rotation time exceeds 2s per <math>90^\circ</math>, kinetic energy is calculated with rotation time of 2s per <math>90^\circ</math>.</li> <li>If the allowable value is exceeded, an external cushioning mechanism, such as an absorber, needs to be installed.</li> </ul>   | $E = \frac{1}{2} I \omega^2$ $\omega = \frac{2\Theta}{t}$ <p>Kinetic energy</p> $E = \frac{1}{2} \times 0.003896 \times \left(\frac{2 \times \pi}{4^2}\right)^2 = 0.0048 \text{ [J]}$ <p>(<math>t</math> is calculated with 2s per <math>90^\circ</math>).</p> <p>0.0048 [J] &lt; Allowable energy    OK</p>   |
| <p><b>6</b> <b>Checking allowable force</b></p> <p>Check if the load applied to the product is within the allowable range.</p> <p>⇒ P.49</p>  | <ul style="list-style-type: none"> <li>If the allowable value is exceeded, an external bearing needs to be installed.</li> </ul>   | $M = 0.4 \times 9.8 \times 0.05 + 0.2 \times 9.8 \times 0.1$ $= 0.392 \text{ (N.m)}$ <p>0.392 [N.m] &lt; Allowable moment load    OK</p>   |

**Load type**

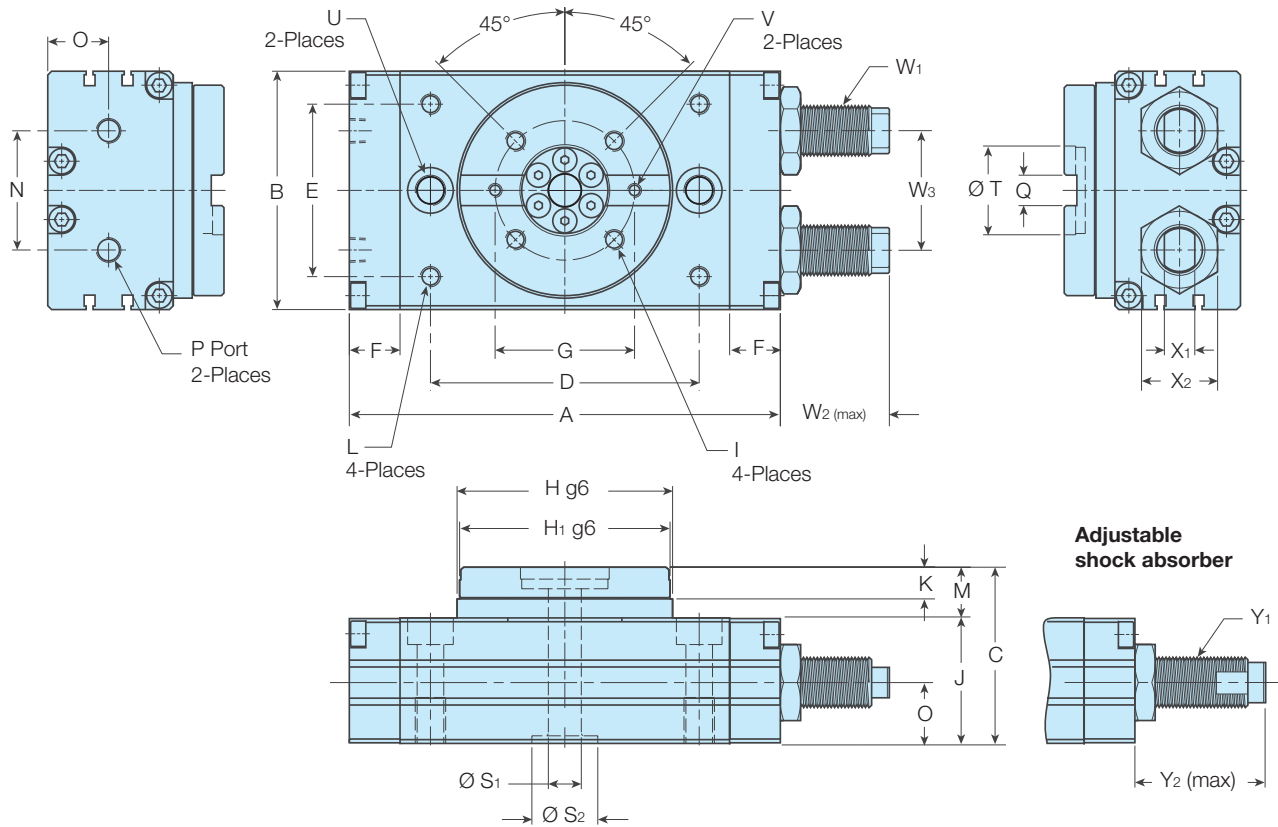
Necessary torque calculation method depends on the load type, Refer to the table below.

| Load type   |  |   |
|---|--|---|
| Static load: Ts   | Resistance load: Tf  | Inertial load: Ta   |
| <p>Only pressing force is necessary (e.g. for clamping)</p>    | <p>Weight or friction force is applied to rotating direction.</p>   | <p>Rotate the load with inertia.</p>    |
| <p><math>T_s = F l</math></p> <p>Ts : Static load (N.m)<br/>           F : Clamping force (N)<br/>           l : Distance from the rotation centre to the clamping position (m)</p>   | <p>Gravity is applied in rotation direction</p> <p><math>T_f = m g l</math></p> <p>Friction force is applied in rotating direction.</p> <p><math>T_f = \mu m g l</math></p> <p>Tf : Resistance load (N.m)<br/>           m : Load mass (kg)<br/>           g : Gravitational acceleration 9.8 (m/s<sup>2</sup>)<br/>           l : Distance from the rotation centre to the point of application of the weight or friction force (m)<br/>           μ : Friction coefficient</p> | <p><math>T_a = I \omega = I \frac{2\Theta}{t^2}</math></p> <p>Ta : Inertial load (N.m)<br/>           I : Moment of inertia (kg m<sup>2</sup>)<br/>           ω : Angular acceleration (rad/s<sup>2</sup>)<br/>           Θ : Rotation angle (rad)<br/>           t : Rotation time (s)</p> <p>For low speed rotary, if the rotation time exceeds 2s per 90°, inertial load is calculated with rotation time of 2s per 90°.</p> |
| <p>Necessary torque: T = Ts</p>   | <p>Necessary torque: T = Tf x (3 to 5) <sup>Note1)</sup></p>   | <p>Necessary torque: T = Ta x 10 <sup>Note2)</sup></p>  |
| <p>* Resistance load: Gravity or friction force is applied to rotating direction.<br/>           Ex, 1) Rotation shaft is horizontal (lateral) and the rotation centre and the centre of gravity of the load are not concentric.<br/>           Ex, 2) Load moves by sliding on the floor.</p> <p>Note 1) The total of resistance load and inertial load is the necessary torque, T = Tf x (3 to 5) + Ta x 10<br/>           Note 2) To adjust the speed, margin is necessary for Tf and Ta.</p> <p>* Not resistance load: Nor weight nor friction forces are applied in rotating direction.<br/>           Ex, 1) Rotation shaft is vertical (up and down)<br/>           Ex, 2) Rotation shaft is horizontal (lateral) and rotation centre and the centre of gravity of the load are not concentric.</p> <p>Note) Necessary torque is inertial load only. T = Ta x 10</p> |  |   |

**Calculating the moment of inertia**

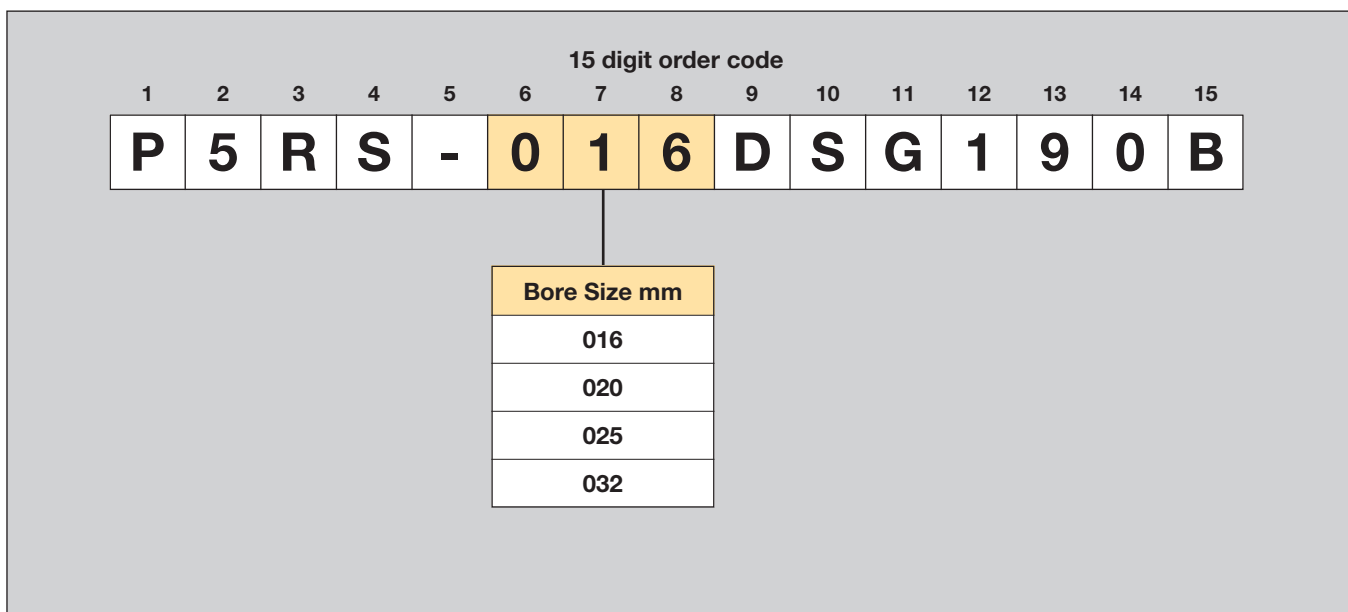
| Shape                                    | Sketch  | Requirement   | Inertia moment I (kgcm <sup>2</sup> )  | Radius of gyration                      | Remarks  |
|--|---|---|--|---|--|
| Disc                                     |    | Diameter d (cm)<br>Mass m (kg)  | $I = m \cdot \frac{d^2}{8}$  | $\frac{d^2}{8}$                         |  |
| Stepped disc                             |    | Diameter d <sub>1</sub> (cm)<br>Diameter d <sub>2</sub> (cm)<br>Mass portion d <sub>1</sub> m <sub>1</sub> (kg)<br>Mass portion d <sub>2</sub> m <sub>2</sub> (kg)  | $I = m_1 \cdot \frac{d_1^2}{8} + m_2 \cdot \frac{d_2^2}{8}$  | -                                       | When portion d <sub>2</sub> is much smaller than portion d <sub>1</sub> , value of d <sub>2</sub> is negligible. |
| Bar (with rotating center at the end)    |    | Bar length l (cm)<br>Mass m (kg)  | $I = m \cdot \frac{l^2}{3}$  | $\frac{l^2}{3}$                         | If the ratio of the bar width : length is over 0.3, use formula for rectangle.                                   |
| Rectangular parallelepiped               |   | Side length a (cm)<br>Side length b (cm)<br>Distance between the center of gravity and rotation l (cm)<br>Mass m (kg)   | $I = m \cdot (l^2 + \frac{a^2+b^2}{12})$   | $l^2 + \frac{a^2+b^2}{12}$              |  |
| Bar (with rotating center at the center) |  | Bar length l (cm)<br>Mass m (kg)  | $I = m \cdot \frac{l^2}{12}$   | $\frac{l^2}{12}$                        | If the ratio of the bar width : length is over 0.3, use formula for rectangle.                                   |
| Rectangular parallelepiped               |  | Side length a (cm)<br>Side length b (cm)<br>Mass m (kg)   | $I = m \cdot \frac{a^2+b^2}{12}$   | $\frac{a^2+b^2}{12}$                    |  |
| Concentrated load                        |  | Shape of concentrated load Disc<br>Diameter of disc d (cm)<br>Arm length l (cm)<br>Mass of concentrated load m <sub>1</sub> (kg)<br>Mass of arm m <sub>2</sub> (kg) | $I = m_1 \cdot l^2 + m_1 \cdot K_1^2 + m_2 \cdot \frac{l^2}{12}$<br>Case of disc $K_1^2 = \frac{d^2}{8}$ | $K_1^2$ : Select from above this column | If m <sub>2</sub> is much smaller than m <sub>1</sub> , assume m <sub>2</sub> to be 0 for calculation.           |

**Dimensions (mm)**



| Bore mm | A              | B                | C                | D   | E  | F    | G         | H    | H <sub>1</sub> | I                   | J              | K              | L              | M              | N              | O    | P     | Q  |
|---------|----------------|------------------|------------------|-----|--|------|-----------|------|----------------|---------------------|----------------|----------------|----------------|----------------|----------------|------|-------|--|
| 16      | 108            | 58               | 47               | 62  | 38   | 15   | 38        | 50   | 48             | M5 x 7 Dp, P.C.D38  | 33             | 8              | M5 x 8 Dp      | 14             | 26             | 15.5 | G 1/8 | 8 <sup>+0.03</sup> <sub>-0</sub> x 3.3 Dp  |
| 20      | 128            | 68               | 55               | 78  | 47   | 15   | 46        | 62.5 | 60             | M6 x 7 Dp, P.C.D46  | 38             | 10             | M6 x 8 Dp      | 17             | 27             | 18.5 | G 1/8 | 10 <sup>+0.03</sup> <sub>-0</sub> x 3.5 Dp |
| 25      | 135.5          | 77               | 58.5             | 84  | 55   | 15.5 | 48        | 67   | 65             | M6 x 9 Dp, P.C.D48  | 41.5           | 10             | M6 x 8 Dp      | 17             | 37             | 20   | G 1/8 | 12 <sup>+0.03</sup> <sub>-0</sub> x 4 Dp   |
| 32      | 170            | 94               | 69.5             | 106 | 68   | 20   | 55        | 85   | 83             | M8 x 10 Dp, P.C.D55 | 49.5           | 12.5           | M8 x 8.5 Dp    | 20             | 47             | 24   | G 1/8 | 12 <sup>+0.03</sup> <sub>-0</sub> x 5 Dp   |
| Bore mm | S <sub>1</sub> | S <sub>2</sub>   | T                |     | U  |      | V         |      | W <sub>1</sub> | W <sub>2</sub>      | W <sub>3</sub> | X <sub>1</sub> | X <sub>2</sub> | Y <sub>1</sub> | Y <sub>2</sub> |      |       |  |
| 16      | 6              | 17 (H7) x 2.5 Dp | 24 (H7) x 3 Dp   |     | 2-Ø 6.8 thru, Ø11 x 6.5 Dp, M8 x 12 Dp (Sink)    |      | M3 x 4 Dp |      | M10 x 1,0      | 27                  | 26             | 7              | 17             | N/A            | N/A            |      |       |  |
| 20      | 10             | 22 (H7) x 2.5 Dp | 32 (H7) x 3 Dp   |     | 2-Ø 8.6 thru, Ø14 x 8.5 Dp, M10 x 15 Dp (Sink)   |      | M4 x 6 Dp |      | M12 x 1,0      | 23                  | 32             | 8              | 19             | N/A            | N/A            |      |       |  |
| 25      | 13             | 22 (H7) x 3 Dp   | 32 (H7) x 3.7 Dp |     | 2-Ø 8.6 thru, Ø14 x 8.5 Dp, M10 x 15 Dp (Sink)   |      | M4 x 5 Dp |      | M14 x 1,5      | 36                  | 37             | 8              | 22             | MC150M         | 52             |      |       |  |
| 32      | 13             | 26 (H7) x 3 Dp   | 35 (H7) x 4.7 Dp |     | 2-Ø 10.5 thru, Ø18 x 10.5 Dp, M12 x 18 Dp (Sink) |      | M5 x 5 Dp |      | M20 x 1.5      | 43                  | 47             | 12             | 30             | MC225M         | 62             |      |       |  |

**Order Key Code**



**Note :** All rotary actuators are supplied magnetic for optional sensing

**Ordering Information: P5RS**

| Description                    | Ports (BSPP) | Rotation    | Torque (Nm at 5 bar) | Weight (kg) | Order code             |
|--------------------------------|--------------|-------------|----------------------|-------------|------------------------|
| Rotary table, stroke adjusters | 1/8          | 190 degrees | 1.21                 | 0.7         | <b>P5RS-016DSG190B</b> |
| Rotary table, stroke adjusters | 1/8          | 190 degrees | 2.51                 | 1.16        | <b>P5RS-020DSG190B</b> |
| Rotary table, stroke adjusters | 1/8          | 190 degrees | 4.91                 | 1.57        | <b>P5RS-025DSG190B</b> |
| Rotary table, stroke adjusters | 1/8          | 190 degrees | 9.86                 | 3.07        | <b>P5RS-032DSG190B</b> |

**Note:** Above units are supplied with rubber buffer stroke adjustment bolts.

**Optional Shock Absorbers**

| Bore mm | Rotary Actuator | Order code    |
|---------|-----------------|---------------|
| 16      | P5RS-016DSG190B | <b>N/A</b>    |
| 20      | P5RS-020DSG190B | <b>N/A</b>    |
| 25      | P5RS-025DSG190B | <b>MC150M</b> |
| 32      | P5RS-032DSG190B | <b>MC225M</b> |

**Reed sensors**

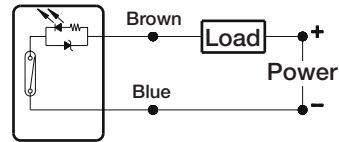
Reed type sensors are based on proven reed switch technology and provide reliable function in many applications. Simple installation and the available AC voltage range are advantages for this range of sensors.

**Technical data**

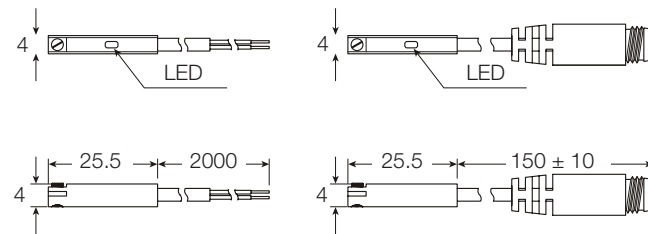
|                   |                                      |
|-------------------|--------------------------------------|
| Design            | Reed element                         |
| Installation      | Mounts within cylinder switch groove |
| Outputs           | Normally open                        |
| Voltage range     | 5-120 V DC/AC                        |
| Voltage drop      | 3.5 V max                            |
| Switching current | 100 mA max                           |
| Switch rating     | 10 W max                             |
| Encapsulation     | IP67 (NEMA 6)                        |
| Temperature range | -10°C to +70°C                       |
| Indication        | LED Red                              |
| Cable             | Polyurethane                         |

**Schematic**

**Reed type**

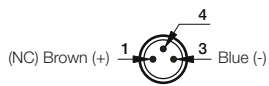


**Dimensions**

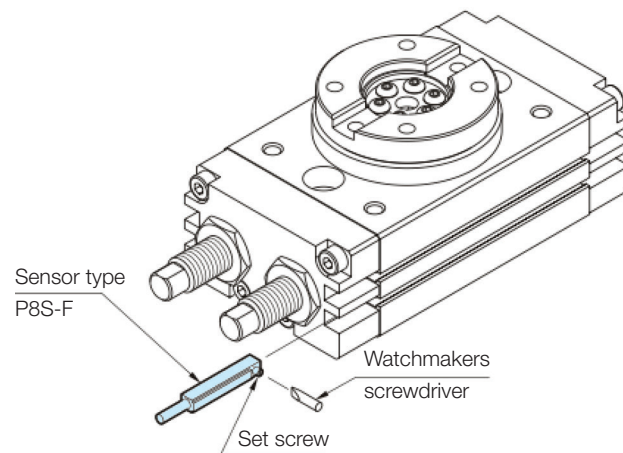


**M8 Quick Connector**

**2 wire QD wiring**



**Installation of Sensor**



**Reed Sensors**

| Size                     | Description                                  | Order code       |
|--------------------------|--|------------------|
| <b>Flush Mount Style</b> |  |                  |
| Reed Type, normally open | 0.15 m PUR cable and M8 screw male connector | <b>P8S-FRSUS</b> |
| Reed Type, normally open | 2 m PUR cable without connector              | <b>P8S-FRFXS</b> |

### Connecting cables with one connector

The cables have an integral snap-in female connector.



| Type of cable   | Cable/connector              | Weight<br>kg | Order code        |
|---|------------------------------|--------------|-------------------|
| <b>Cables for sensors, complete with one female connector</b> |                              |              |                   |
| Cable, Flex PVC   | 3 m, 8 mm Snap-in connector  | 0.07         | <b>9126344341</b> |
| Cable, Flex PVC   | 10 m, 8 mm Snap-in connector | 0.21         | <b>9126344342</b> |
| Cable, Super Flex PVC   | 3 m, 8 mm Snap-in connector  | 0.07         | <b>9126344343</b> |
| Cable, Super Flex PVC   | 10 m, 8 mm Snap-in connector | 0.21         | <b>9126344344</b> |
| Cable, Polyurethane   | 3 m, 8 mm Snap-in connector  | 0.01         | <b>9126344345</b> |
| Cable, Polyurethane   | 10 m, 8 mm Snap-in connector | 0.20         | <b>9126344346</b> |

### Male connectors for connecting cables

Cable connectors for producing your own connecting cables.  
 The connectors can be quickly attached to the cable without special tools.  
 Only the outer sheath of the cable is removed. The connectors are available for M8 and M12 screw connectors and meet protection class IP 65.



| Connector           | Weight<br>kg | Order code        |
|---------------------|--------------|-------------------|
| M8 screw connector  | 0,017        | <b>P8SCS0803J</b> |
| M12 screw connector | 0,022        | <b>P8SCS1204J</b> |

### Ready to use connecting cables with connectors at each end

As accessories the system comprises a large number of different cables in order to meet all requirements that may arise and to make the installation simple, fast and reliable.

Cables with moulded 8 mm snap-in round contacts in both ends.  
 The cables are available in two types, one with a straight male and female connectors respectively, and one with a straight 3-pole male connector in one end and an angled 3-pole female connector in the other end.



#### Technical data

##### Contacts

Moulded 8 mm snap-in male/female contacts.  
 Enclosure IP67

##### Cable

Conductor 3x0,25 mm<sup>2</sup> (32x0,10 mm<sup>2</sup>)  
 Sheath PVC/PUR  
 Colour Black

## Installation and Maintenance



Disconnect air and electrical supplies before attempting repair or maintenance.  
 See ISO 4414-1982 for safety requirements covering the installation and use of pneumatic equipment.

**To prevent sudden movement of the unit during start up, to prevent sudden damage and possible movement, controlled introduction of air supply pressure by use of a soft start valve is recommended.**

## Selection

**1 Do not apply a load over the operating limit range.**

Select the model considering max. allowable load and allowable moment. When actuator is used outside of operating limits, eccentric loads on guide will be in excess this causing vibration on guide and inaccuracy and shortens life

**2 Do not apply excessive forces and impacts.**

This will cause problems and possible failure.

## Mounting

The rotary unit can be fastened to a static or a moving part. When on a moving part, you must pay attention to the forces created by inertia over the unit and its load.

Do not exceed the maximum loading and operating speed limitation, it will affect the life cycle of the product

This product can only be actuated via air pressure, operation air pressure range 1~9 bar. Hydraulic actuation is not applicable.

No magnetic items should be placed nearby, it will affect the sensors operating function.

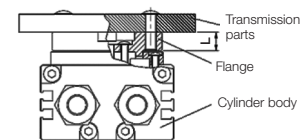
Do not apply this product as a shock absorbing device

Do not reprocess this product. It will affect the product intensity and durability to drop.

Do not rotate the cylinder to the end of the stroke when fixing (assembling) the transmission parts, it could cause the life expectancy of the the gear shaft to drop.

Stabilize the cylinder body when assembling the transmission parts. The screw depth of the transmission parts should not exceed the thickness of flange. Please refer to the chart below.

Environment temperature: -5 °C~60 °C



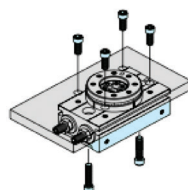
### Variety of Installation options for space saving

Offers maximum space saving installation by taking advantage of the compact body, space saving wiring and piping.

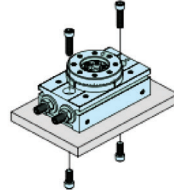
| Model    | Screw length (L) on transmission |
|----------|----------------------------------|
| P5RS-016 | 7                                |
| P5RS-020 | 9.5                              |
| P5RS-020 | 9.5                              |
| P5RS-025 | 11.5                             |

#### Free mount

##### Top mounting



##### Bottom mounting

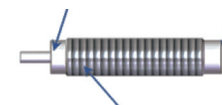


## Shock Absorbers

1. Disassembly of the shock absorber is strictly prohibited. Disassembly of the shock absorber will cause failure and leakage.
2. Do not cause any damage to the surface of the shock absorber piston rod. It would lower the products durability and ability to retract and stretch.

3. The shock absorber is considered a consumable item. Therefore it is crucial to replace the shock absorber when absorber performance drops.

Do not disassemble the shock absorber



Piston rod (Do not damage the surface)

## Environment

**1 Do not use in atmosphere where the actuator contacts directly the liquid such as cutting oil.**

Conditions where the rotary actuator is exposed directly to cutting oil, coolant and oil mist can lead to vibration, increase of moving part resistance, air leakage, etc.

**2 Do not use in atmosphere where the rotary actuator contacts directly the material such as powder dust, dust, spatter etc.**

**3 Do not use in direct sun light.**

**4 Do not use in environment where there is heat source.**

Use a cover when there is a heat source around the rotary actuator, or if temperature of product increases and exceeds operating temperature range by emissive heat.

**5 Do not subject it to excessive vibration and/or impact.**

This results in damage and/or malfunction.

Contact Parker if the actuator is used in the above conditions.

# Specifying air quality (purity) in accordance with ISO8573-1:2010, the international standard for Compressed Air Quality

ISO8573-1 is the primary document used from the ISO8573 series as it is this document which specifies the amount of contamination allowed in each cubic metre of compressed air.

ISO8573-1 lists the main contaminants as Solid Particulate, Water and Oil. The purity levels for each contaminant are shown separately in tabular form, however for ease of use, this document combines all three contaminants into one easy to use table.

| ISO8573-1:2010 CLASS | Solid Particulate  |                |              |                                      | Water                    |                         | Oil   |
|----------------------|--|----------------|--------------|--------------------------------------|--------------------------|-------------------------|---|
|                      | Maximum number of particles per m <sup>3</sup>                                 |                |              | Mass Concentration mg/m <sup>3</sup> | Vapour Pressure Dewpoint | Liquid g/m <sup>3</sup> | Total Oil (aerosol liquid and vapour) mg/m <sup>3</sup> |
|                      | 0,1 - 0,5 micron   | 0,5 - 1 micron | 1 - 5 micron |                                      |                          |                         |   |
| 0                    | As specified by the equipment user or supplier and more stringent than Class 1 |                |              |                                      |                          |                         |   |
| 1                    | ≤ 20 000   | ≤ 400          | ≤ 10         | -                                    | ≤ -70 °C                 | -                       | 0,01  |
| 2                    | ≤ 400 000  | ≤ 6 000        | ≤ 100        | -                                    | ≤ -40 °C                 | -                       | 0,1   |
| 3                    | -  | ≤ 90 000       | ≤ 1 000      | -                                    | ≤ -20 °C                 | -                       | 1   |
| 4                    | -  | -              | ≤ 10 000     | -                                    | ≤ +3 °C                  | -                       | 5   |
| 5                    | -  | -              | ≤ 100 000    | -                                    | ≤ +7 °C                  | -                       | -   |
| 6                    | -  | -              | -            | ≤ 5                                  | ≤ +10 °C                 | -                       | -   |
| 7                    | -  | -              | -            | 5 - 10                               | -                        | ≤ 0,5                   | -   |
| 8                    | -  | -              | -            | -                                    | -                        | 0,5 - 5                 | -   |
| 9                    | -  | -              | -            | -                                    | -                        | 5 - 10                  | -   |
| X                    | -  | -              | -            | > 10                                 | -                        | > 10                    | > 10  |

## Specifying air purity in accordance with ISO8573-1:2010

When specifying the purity of air required, the standard must always be referenced, followed by the purity class selected for each contaminant (a different purity class can be selected for each contamination if required).

An example of how to write an air quality specification is shown below:

### ISO 8573-1:2010 Class 1.2.1

ISO 8573-1:2010 refers to the standard document and its revision, the three digits refer to the purity classifications selected for solid particulate, water and total oil. Selecting an air purity class of 1.2.1 would specify the following air quality when operating at the standard's reference conditions :

#### Class 1 - Particulate

In each cubic metre of compressed air, the particulate count should not exceed 20,000 particles in the 0.1 - 0.5 micron size range, 400 particles in the 0.5 - 1 micron size range and 10 particles in the 1 - 5 micron size range.

#### Class 2 - Water

A pressure dewpoint (PDP) of -40°C or better is required and no liquid water is allowed.

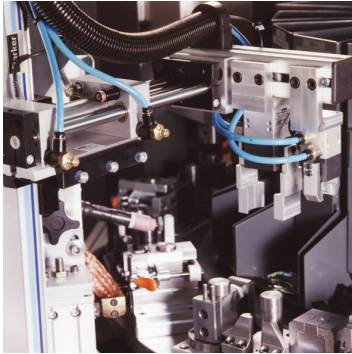
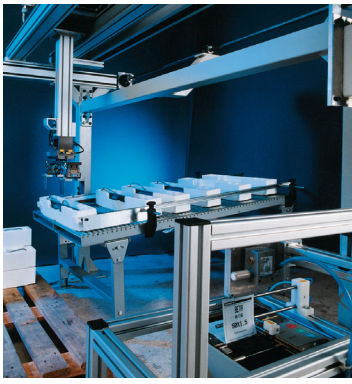
#### Class 1 - Oil

In each cubic metre of compressed air, not more than 0.01mg of oil is allowed. This is a total level for liquid oil, oil aerosol and oil vapour.

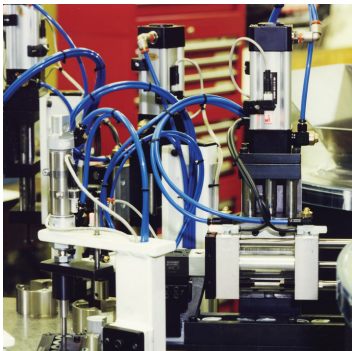
## ISO8573-1:2010 Class zero

- **Class 0 does not mean zero contamination.**
- **Class 0 requires the user and the equipment manufacturer to agree contamination levels as part of a written specification.**
- **The agreed contamination levels for a Class 0 specification should be within the measurement capabilities of the test equipment and test methods shown in ISO8573 Pt 2 to Pt 9.**
- **The agreed Class 0 specification must be written on all documentation to be in accordance with the standard.**
- **Stating Class 0 without the agreed specification is meaningless and not in accordance with the standard.**
- **A number of compressor manufacturers claim that the delivered air from their oil-free compressors is in compliance with Class 0.**
- **If the compressor was tested in clean room conditions, the contamination detected at the outlet will be minimal. Should the same compressor now be installed in typical urban environment, the level of contamination will be dependent upon what is drawn into the compressor intake, rendering the Class 0 claim invalid.**
- **A compressor delivering air to Class 0 will still require purification equipment in both the compressor room and at the point of use for the Class 0 purity to be maintained at the application.**
- **Air for critical applications such as breathing, medical, food, etc typically only requires air quality to Class 2.2.1 or Class 2.1.1.**
- **Purification of air to meet a Class 0 specification is only cost effective if carried out at the point of use.**



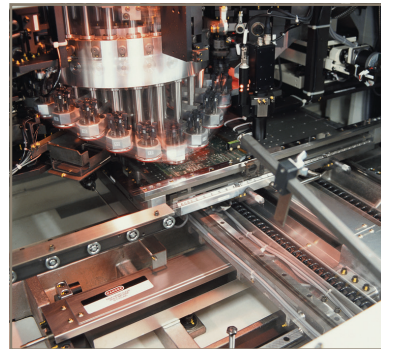


aerospace  
climate control  
electromechanical  
filtration  
fluid & gas handling  
hydraulics  
pneumatics  
process control  
sealing & shielding




# Slide Tables P5SS Series

Sizes 6, 8, 12, 16, 20 and 25 mm




ENGINEERING YOUR SUCCESS.

| <b>Contents</b>                                | <b>page</b> |
|--|-------------|
| P5SS Slide Tables General Technical Data ..... | 65          |
| Features .....                                 | 66-67       |
| Operating and Environmental Data .....         | 68          |
| Material Specification .....                   | 68          |
| Selection Flow Chart .....                     | 69          |
| Table Deflection .....                         | 71          |
| <br><b>Dimensions</b>                          |             |
| Slide Table Ø6 .....                           | 73          |
| Slide Table Ø8 .....                           | 74          |
| Slide Table Ø12 .....                          | 75          |
| Slide Table Ø16 .....                          | 76          |
| Slide Table Ø20 .....                          | 77          |
| Slide Table Ø25 .....                          | 78          |
| Order Code Key .....                           | 79          |
| Accessories Ø6 - Ø25 Stroke Adjusters .....    | 80          |
| Accessories Ø8 - Ø25 Stroke Absorbers .....    | 81          |
| P8S Sensors .....                              | 83          |
| Installation and Maintenance .....             | 86          |




**Important**

Before attempting any external or internal work on the cylinder or any connected components, make sure the cylinder is vented and disconnect the air supply in order to ensure isolation of the air supply.



**Note**

All technical data in this catalogue are typical data only.  
 Air quality is essential for maximum cylinder service life (see ISO 8573).



**WARNING**

**FAILURE OR IMPROPER SELECTION OR IMPROPER USE OF THE PRODUCTS AND/OR SYSTEMS DESCRIBED HEREIN OR RELATED ITEMS CAN CAUSE DEATH, PERSONAL INJURY AND PROPERTY DAMAGE.**

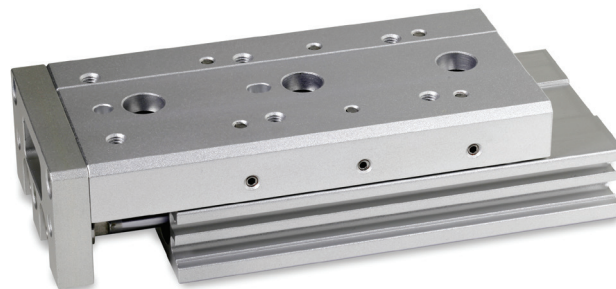
This document and other information from Parker Hannifin Corporation, its subsidiaries and authorized distributors provide product and/or system options for further investigation by users having technical expertise. It is important that you analyze all aspects of your application and review the information concerning the product or system in the current product catalog. Due to the variety of operating conditions and applications for these products or systems, the user, through its own analysis and testing, is solely responsible for making the final selection of the products and systems and assuring that all performance, safety and warning requirements of the application are met. The products described herein, including without limitation, product features, specifications, designs, availability and pricing, are subject to change by Parker Hannifin Corporation and its subsidiaries at any time without notice.

**SALE CONDITIONS**

The items described in this document are available for sale by Parker Hannifin Corporation, its subsidiaries or its authorized distributors. Any sale contract entered into by Parker will be governed by the provisions stated in Parker's standard terms and conditions of sale (copy available upon request).

### P5SS - Slide Tables

The Slide Table P5SS is a pneumatic actuator, operated by two cylinders mounted in parallel for moving loads fitted on its mobile carriage or on its front plate quickly and accurately. Optional end of stroke adjusters offer precise adjustment even when the slide table is pressurised.



- High precision
- Bores Ø6, 8, 12, 16, 20 and 25mm
- Combination of dual bore cylinder and linear rail
- Magnetic piston standard
- Rubber bumper standard
- Optional stroke adjusters available
- Optional shock absorbers available

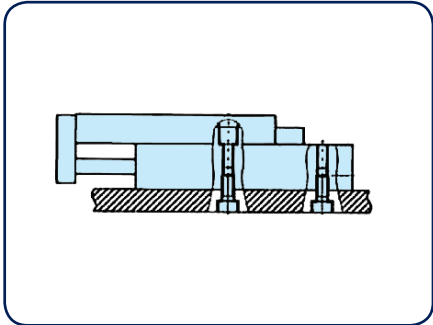
### General technical data

| Size  | 6                                   | 8        | 12       | 16        | 20        | 25        |
|---|-------------------------------------|----------|----------|-----------|-----------|-----------|
| Stroke (mm)                                       | See chart per size and stroke       |          |          |           |           |           |
| Max stroke (mm)                                   | 50                                  | 75       | 100      | 125       | 125       | 150       |
| Stroke length tolerance (mm)                      | 0 / +1                              |          |          |           |           |           |
| Ø Piston bore (mm)                                | 2 x 6                               | 2 x 8    | 2 x 12   | 2 x 16    | 2 x 20    | 2 x 25    |
| Ø Air port size (mm)                              | M3                                  | M5       |          |           | G1/8      |           |
| Speed (mm/s)                                      | 50 to 500                           |          |          |           |           |           |
| Force OUT (N)*                                    | 29                                  | 51       | 113      | 201       | 314       | 491       |
| Force IN (N)*                                     | 21                                  | 38       | 85       | 151       | 236       | 378       |
| Sensing   | Magnet in                           |          |          |           |           |           |
| Max kinetic energy (mJ) elastic bumpers           | 18                                  | 27       | 55       | 110       | 160       | 240       |
| Max kinetic energy (mJ) hydraulic shocks          | -                                   | 45       | 110      | 220       | 320       | 480       |
| Max allowable static load (kg) on the carriage    | 0.6                                 | 1        | 2        | 4         | 6         | 9         |
| Max allowable static load (kg) on the front plate | 0.36                                | 0.6      | 1.2      | 2.4       | 3.6       | 5.4       |
| Max allowable static moments (Nm)                 | See chart per size and stroke       |          |          |           |           |           |
| End stroke threads size                           | M5 x 0.8                            | M8 x 1.0 | M8 x 1.0 | M10 x 1.0 | M14 x 1.5 | M14 x 1.5 |
| Weight (g) without elastic bumpers                | See chart per size and stroke       |          |          |           |           |           |
| Additional weight (g) elastic bumpers OUT         | 10                                  | 15       | 30       | 50        | 100       | 150       |
| Additional weight (g) elastic bumpers IN          | 5                                   | 9        | 10       | 30        | 70        | 125       |
| Weight (g) without hydraulic shocks               | See chart per size and stroke       |          |          |           |           |           |
| Additional weight (g) hydraulic shocks OUT        | -                                   | 35       | 50       | 80        | 170       | 215       |
| Additional weight (g) hydraulic shocks IN         | -                                   | 45       | 60       | 105       | 205       | 300       |
| Max. temperature (C°)                             | -10° to +60°                        |          |          |           |           |           |
| Air pressure (bar)                                | 1,5 to 7                            |          |          |           |           |           |
| Type of drive                                     | Twin piston in parallel             |          |          |           |           |           |
| Operation   | Dry air, lubricated or unlubricated |          |          |           |           |           |

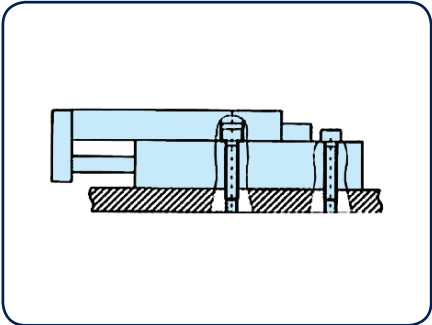
\* At 5 bar

**Flexible Installation**

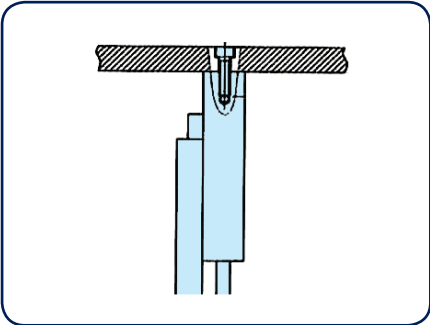
**Horizontal mounting  
 (Body tapped)**



**Horizontal mounting  
 (Through hole)**



**Vertical mounting  
 (Body tapped)**



**Installation Sizes**

| Model    | A with stroke (mm) |     |     |     |     |     |     |     |     | B (mm) | C (mm) |
|----------|--------------------|-----|-----|-----|-----|-----|-----|-----|-----|--------|--------|
|          | 10                 | 20  | 30  | 40  | 50  | 75  | 100 | 125 | 150 |        |        |
| P5SS-006 | 48                 | 58  | 68  | 90  | 106 | -   | -   | -   | -   | 32     | 20     |
| P5SS-008 | 56                 | 61  | 72  | 90  | 108 | 158 | -   | -   | -   | 40     | 24     |
| P5SS-012 | 80                 | 80  | 80  | 92  | 112 | 158 | 212 | -   | -   | 50     | 32     |
| P5SS-016 | 87                 | 87  | 87  | 87  | 112 | 162 | 210 | 260 | -   | 62     | 40     |
| P5SS-020 | 97                 | 97  | 97  | 107 | 122 | 161 | 214 | 268 | 320 | 76     | 50     |
| P5SS-025 | 108                | 108 | 108 | 118 | 131 | 172 | 213 | 271 | 311 | 92     | 62     |

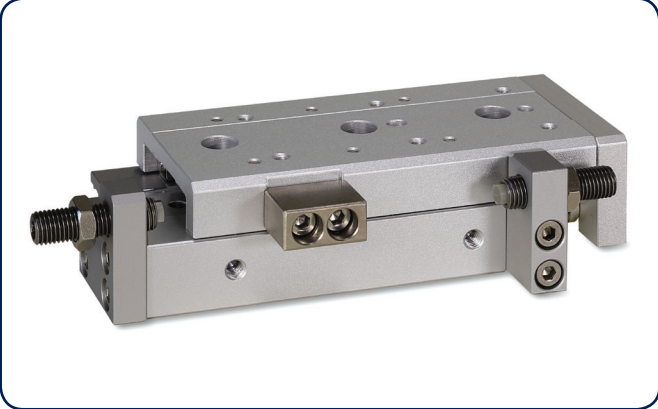
Dimensions shown are inclusive of stroke length  
 Dimensions shown are for basic unit only and do not include optional stroke adjusters



**Tapped tool plate**



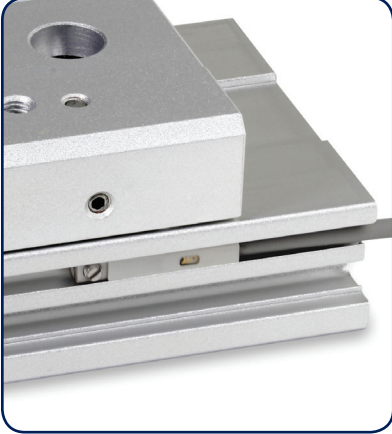
**Optional Adjustment Bolts**



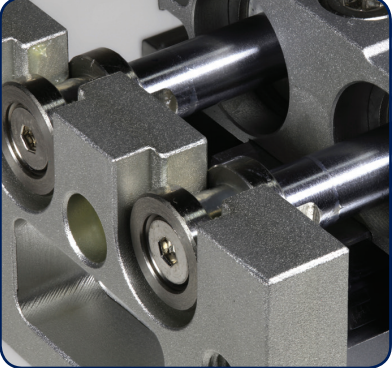
**Optional Shock Absorbers**



**Integrated protected sensor grooves**



**Twin cylinder - Increased thrust to profile ratio**



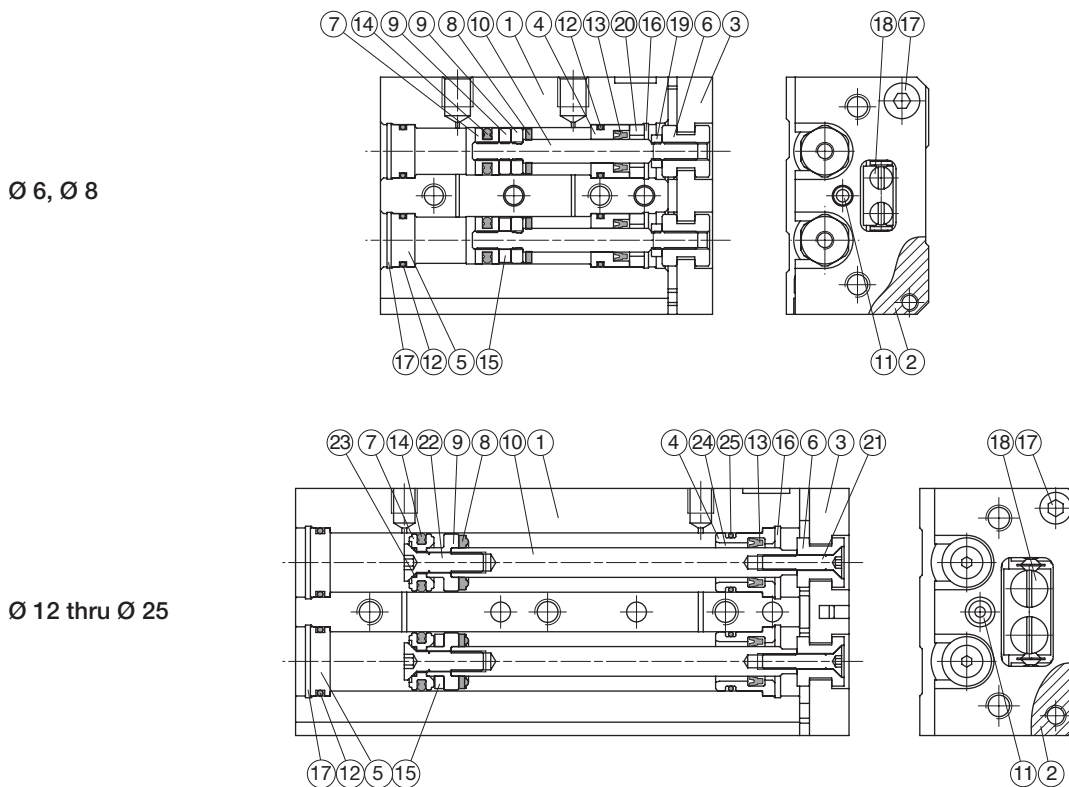
**Weight (g)**

| Stroke (mm) | Bore (mm) |     |     |      |      |      |
|-------------|-----------|-----|-----|------|------|------|
|             | Ø6        | Ø8  | Ø12 | Ø16  | Ø20  | Ø25  |
| 10          | 78        | 137 | 335 | 536  | 1001 | 1573 |
| 20          | 98        | 148 | 339 | 546  | 1012 | 1587 |
| 30          | 111       | 171 | 343 | 552  | 1020 | 1605 |
| 40          | 147       | 216 | 393 | 630  | 1098 | 1735 |
| 50          | 172       | 255 | 482 | 723  | 1254 | 1930 |
| 75          | -         | 367 | 684 | 1030 | 1690 | 2553 |
| 100         | -         | -   | 910 | 1341 | 2214 | 3180 |
| 125         | -         | -   | -   | 1646 | 2729 | 4082 |
| 150         | -         | -   | -   | -    | 3310 | 4420 |

**Operating and environmental data**

|                      |  |
|----------------------|--|
| Operating medium     | For best possible service life and trouble-free operation dry, filtered compressed air to ISO 8573-1:2010 quality class 3.4.3 should be used. This specifies a dew point of +3°C for indoor operation ( a lower dew point should be selected for outdoor operation) and is in line with the air quality from most standard compressors with a standard filter. |
| Operating pressure   | 1.5 bar to 7 bar   |
| Ambient temperature  | -5 °C to +60 °C  |
| Pre-lubricated       | Further lubrication is normally not necessary. If additional lubrication is introduced it must be continued.   |
| Corrosion resistance | Resistance to corrosion and chemicals.   |

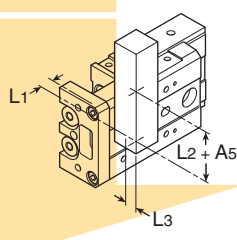
**Material specification**



| Pos | Part               | 6               | 8               | 12 to 25       |
|-----|--------------------|-----------------|-----------------|----------------|
| 1   | Body               |                 | Aluminum alloy  |                |
| 2   | Table              |                 | Aluminum alloy  |                |
| 3   | Plate              |                 | Aluminum alloy  |                |
| 4   | Rod cover          |                 | Aluminum alloy  |                |
| 5   | Head cover         |                 | Aluminum alloy  |                |
| 6   | Floating connector |                 | Stainless steel |                |
| 7   | Piston             | Stainless steel |                 | Aluminum alloy |
| 8   | Cushion pad        |                 | NBR             |                |
| 9   | Spacer ring        | Aluminum alloy  | Stainless steel | Aluminum alloy |
| 10  | Piston rod         |                 | Stainless steel |                |
| 11  | End cushion        |                 | PU              |                |
| 12  | Cover ring         |                 | NBR             |                |
| 13  | Rod packing        |                 | NBR             |                |

| Pos | Part                    | 6               | 8               | 12 to 25        |
|-----|-------------------------|-----------------|-----------------|-----------------|
| 14  | Piston packing          |                 | NBR             |                 |
| 15  | Magnet ring             |                 | Magnet material |                 |
| 16  | Snap ring               | Spring steel    |                 | Stainless steel |
| 17  | Bolt                    |                 | Stainless steel |                 |
| 18  | Slide way               |                 | Bearing steel   |                 |
| 19  | Nut                     | Copper          |                 | —               |
| 20  | Rod cover washer        | Stainless steel |                 | —               |
| 21  | Floating connector bolt | Stainless steel |                 | —               |
| 22  | Piston screw            |                 | —               | Stainless steel |
| 23  | Piston gasket           |                 | —               | NBR             |
| 24  | Rod bush                |                 | Copper          |                 |
| 25  | Cover ring              |                 | NBR             |                 |

Selection Flow Chart

| Operating conditions  | Formula and charts   | Selection example  |
|---|--|--|
| List out the operating conditions according to mounting position and shape of the workpiece | Model used<br>Cushion style<br>Workpiece install position<br>Mounting position<br>Average speed $V_a$ (mm/s)<br>Allowable load $W$ (kg) (Figure 1)<br>Overhang $L_n$ (mm) (Figure 2)   | Cylinder: P5SS-6-10<br>Cushion: Cushion pad<br>Workpiece table mounting<br>Mounting: Lateral mounting<br>Average speed: $V_a = 150$ mm/s<br>Load: $W = 0.3$ kg<br>$L_1 = 4$ mm<br>$L_2 = 4$ mm<br>$L_3 = 4$ mm   |
|   |  |   |
| Kinetic energy  |  |  |
| Calculate kinetic energy $E$ (J) of work  | $E = 1/2 \cdot W \cdot (V/1000)^2$   | $E = 1/2 \cdot 0.3 \cdot (210/1000)^2 = 0.0066$  |
| Calculate allowable kinetic energy $E_a$ (J)  | Collision speed $V = 1.4 \cdot V_a$<br>$E_a = K \cdot E_{max}$<br>Workpiece mounting coefficient $K$ : Figure 3  | Collision speed $V = 1.4 \cdot 150 = 210$<br>$E_a = 1 \cdot 0.015 = 0.015$<br>Possible to use by $E = 0.0066 \leq E_a = 0.015$   |
| Make sure that kinetic energy of work is less / lower than allowable kinetic energy.        | Max. allowable kinetic energy $E_{max}$ : Table 1<br>Kinetic energy ( $E$ ) $\leq$ Allowable kinetic energy ( $E_a$ )  |  |
| Load rate   |  |  |
| Load rate of work   |  |  |
| Calculate static work $W_a$ (kg)  | $W_a = K \cdot \beta \cdot W_{max}$<br>Workpiece mounting coefficient $K$ : Figure 3<br>Allowable load coefficient $\beta$ : Figure 4<br>Maximum allowable moment $W_{max}$ : Table 2  | $W_a = 1 \times 1 \times 0.6 = 0.66$<br>$K = 1$<br>$\beta = 1$<br>$W_{max} = 0.6$  |
| Calculate load rate $\alpha_1$ of static work   | $\alpha_1 = W/W_a$   | $\alpha_1 = 0.3/0.6 = 0.5$   |
| Load rate of static moment  |  |  |
| Calculate static moment $M$ (Nm).   | $M = W \times 9.8 \cdot (L_n + A_n)/1000$<br>Correction value for moment center distance $A_n$ : Table 3   | <b>Yawing</b><br>Calculate $M_y$<br>$M_y = W \times 9.8 \cdot (L_1 + A_3)/1000 = 0.3 \times 9.8 \cdot (4 + 13)/1000 = 0.05$<br>$A_3 = 13$<br>$M_{ay} = 1 \times 1 \times 0.7 = 0.7$<br>$M_{y_{max}} = 0.7$<br>$K = 1$<br>$\gamma = 1$  |
| Calculate allowable static moment $M_a$ (Nm).   | $M_a = K \cdot \gamma \cdot M_{max}$<br>Workpiece mounting coefficient $K$ : Figure 3<br>Allowable moment coefficient $\gamma$ : Figure 5<br>Max. allowable moment $M_{max}$ : Table 4   | <b>Rolling</b><br>Calculate $M_r$<br>$M_r = W \times 9.8 \cdot (L_3 + A_2)/1000 = 0.3 \times 9.8 \cdot (5 + 6)/1000 = 0.033$<br>$A_2 = 6$<br>$M_{ar} = 0.7$ (Same value as $M_a$ )   |
| Calculate load rate $\alpha_2$ of static moment   | $\alpha_2 = M/M_a$   | $\alpha_2 = 0.05/0.7 = 0.072$ $\alpha'_2 = 0.033/0.7 = 0.047$  |
| Load rate of kinetic moment   |  |  |
| Calculate kinetic moment $M_e$ (Nm).  | $M_e = 1/3 \cdot W_e \cdot 9.8 \cdot (L_n + A_n)/1000$<br>Collision equivalence load $W_e = \delta \cdot W \cdot V$<br>$\delta$ : Cushion coefficient with cushion pad (Standard) = 4/100 with shock absorber = 1/100                                    | <b>Pitching</b><br>Calculate $M_{ep}$<br>$M_{ep} = 1/3 \times 2.52 \times 9.8 \times (5 + 6)/1000 = 0.09$<br>$W_e = 4/100 \times 0.3 \times 210 = 2.52$  |
| Calculate allowable kinetic moment $M_{ea}$ (Nm).   | Correction value for moment center distance $A_n$ : Table 3<br>$M_{ea} = K \cdot \gamma \cdot M_{max}$<br>Workpiece mounting coefficient $K$ : Figure 3<br>Allowable moment coefficient $\gamma$ : Figure 5<br>Max. allowable moment $M_{max}$ : Table 4 | <b>Yawing</b><br>Calculate $M_{ey}$<br>$M_{ey} = 1/3 \times 2.52 \times 9.8 \times (4 + 16)/1000 = 0.165$<br>$W_e = 2.52$<br>$A_4 = 16$<br>$M_{eap} = 1 \times 0.97 \times 0.7 = 0.679$<br>$M_{ey} = 0.679$ (Same value as $M_{eap}$ )<br>$K = 1$<br>$\gamma = 0.97$<br>$M_{p_{max}} = 0.$ |
| Calculate load rate $\alpha_3$ of kinetic moment.   | $\alpha_3 = M_e/M_{ea}$  | $\alpha_3 = 0.09/0.679 = 0.13$ $\alpha'_3 = 0.165/0.679 = 0.243$   |
| Sum of load rate  |  |  |
| When sum of load rate does not exceed 1, it is possible to use.                             | $\Sigma \alpha_n = \alpha_1 + \alpha_2 + \alpha_3 \leq 1$  | $\Sigma \alpha_n = \alpha_1 + \alpha_2 + \alpha'_2 + \alpha_3 + \alpha'_3 \leq 1$<br>$= 0.5 + 0.072 + 0.047 + 0.133 + 0.243 = 0.995 \leq 1$<br>And it is possible to use.  |

**Table 1: Maximum allowable kinetic energy:  $E_{max}$  (J)**

| Allowable kinetic energy |                |                 |
|--------------------------|----------------|-----------------|
| Cushion pad              | Shock absorber | Model           |
| 0.018                    | —              | <b>P5SS-006</b> |
| 0.027                    | 0.045          | <b>P5SS-008</b> |
| 0.55                     | 0.110          | <b>P5SS-012</b> |
| 0.10                     | 0.220          | <b>P5SS-016</b> |
| 0.60                     | 0.320          | <b>P5SS-020</b> |
| 0.40                     | 0.460          | <b>P5SS-025</b> |

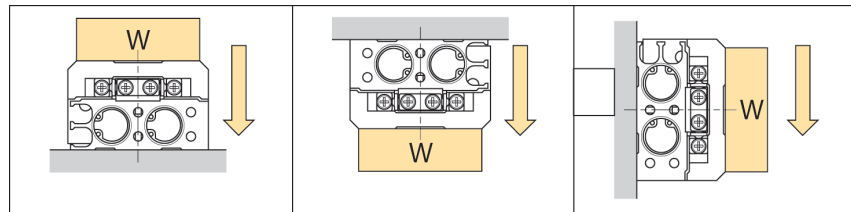
**Table 2: Maximum allowable static load:  $W_{max}$  (kg)**

| Max. allowable kinetic energy | Model           |
|-------------------------------|-----------------|
| 0.6                           | <b>P5SS-006</b> |
| 1                             | <b>P5SS-008</b> |
| 2                             | <b>P5SS-012</b> |
| 4                             | <b>P5SS-016</b> |
| 6                             | <b>P5SS-020</b> |
| 9                             | <b>P5SS-025</b> |

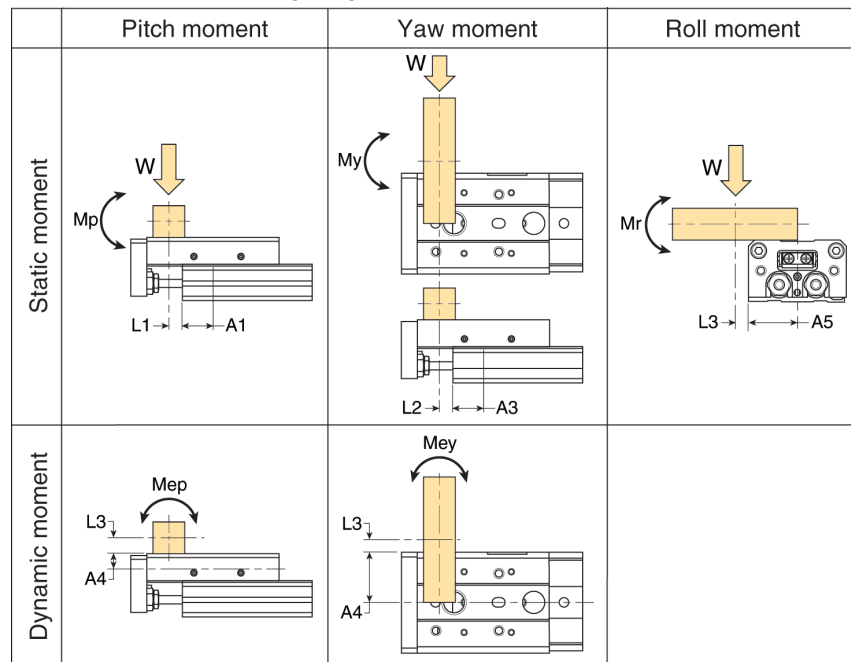
**Table 3: Correction value for moment center distance:  $A_n$  (mm) (Refer to Figure 2)**

| $A_1$ | $A_2$ | $A_3$ | $A_4$ | $A_5$ | Model           |
|-------|-------|-------|-------|-------|-----------------|
| 11    | 6     | 13    | 16    | 16    | <b>P5SS-006</b> |
| 11    | 8     | 13    | 20    | 20    | <b>P5SS-008</b> |
| 24    | 9.5   | 26    | 25    | 25    | <b>P5SS-012</b> |
| 27    | 10.5  | 30    | 31    | 31    | <b>P5SS-016</b> |
| 34    | 15.5  | 36    | 38    | 38    | <b>P5SS-020</b> |
| 42    | 20.5  | 44    | 46    | 46    | <b>P5SS-025</b> |

**Figure 1: Allowable load:  $W$  (kg)**

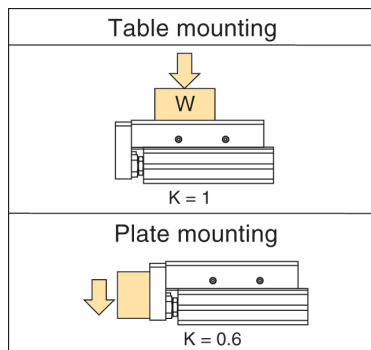


**Figure 2: Overhang:  $L_n$  (mm) Correction value for moment center distance:  $A_n$  (mm)**

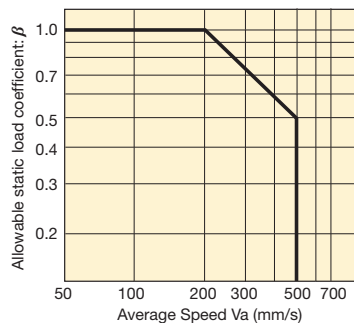


Note: Static moment: Moment by gravity.  
 Kinetic moment: Moment by stopper collision.

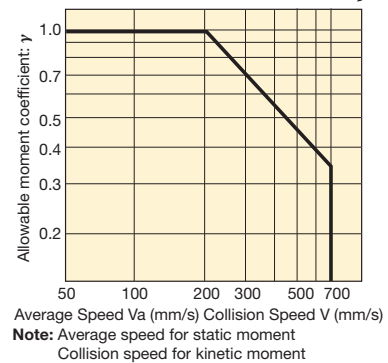
**Figure 3: Workpiece mounting coefficient:  $K$**



**Figure 4: Allowable static load coefficient:  $\beta$**



**Figure 5: Allowable moment coefficient:  $\gamma$**



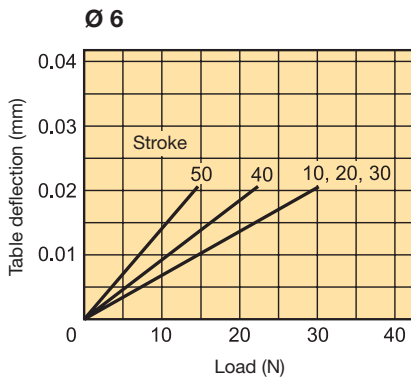
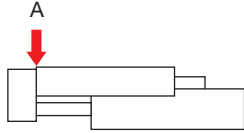
**Table 4: Maximum allowable moment:  $M_{max}$  (Nm)**

| Stroke (mm) |      |      |      |      |      |      |      |      | Model           |
|-------------|------|------|------|------|------|------|------|------|-----------------|
| 10          | 20   | 30   | 40   | 50   | 75   | 100  | 125  | 150  |                 |
| 0.7         | 1.0  | 1.1  | 1.1  | 1.1  | —    | —    | —    | —    | <b>P5SS-006</b> |
| 2.0         | 2.0  | 2.6  | 3.5  | 3.9  | 3.9  | —    | —    | —    | <b>P5SS-008</b> |
| 3.9         | 3.9  | 3.9  | 5.5  | 6.8  | 9.6  | 9.6  | —    | —    | <b>P5SS-012</b> |
| 9.8         | 9.8  | 9.8  | 9.8  | 12.0 | 21.0 | 30.0 | 30.0 | —    | <b>P5SS-016</b> |
| 16.4        | 16.4 | 16.4 | 16.4 | 24.2 | 31.4 | 45.5 | 45.5 | 45.5 | <b>P5SS-020</b> |
| 26.5        | 26.5 | 26.5 | 26.5 | 37.8 | 49.8 | 62.2 | 62.2 | 62.2 | <b>P5SS-025</b> |

**Table deflection**

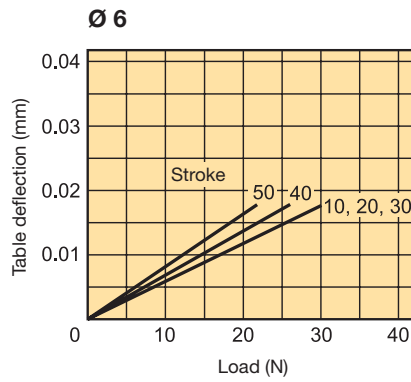
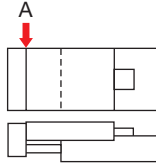
**Table deflection by pitch moment**

Table pitch deflection due to static pitch moment applied at arrow for fully extended stroke of slide table.



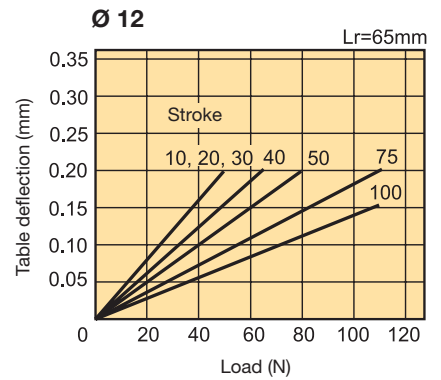
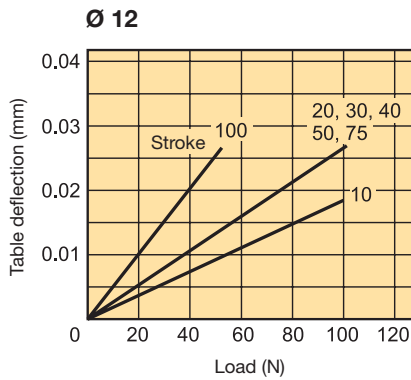
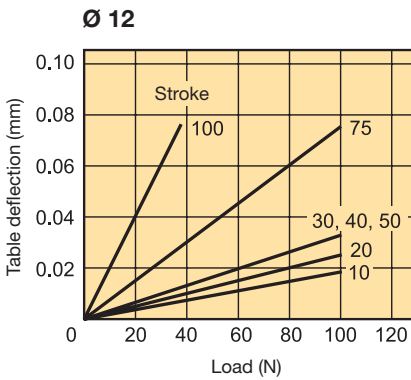
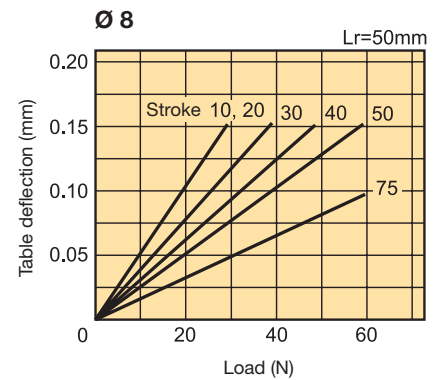
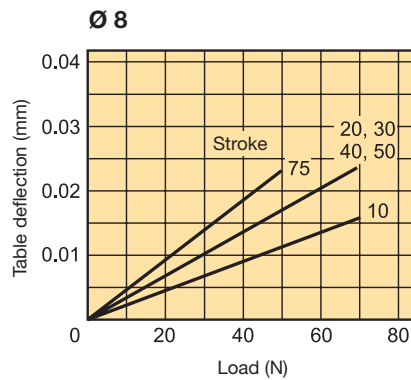
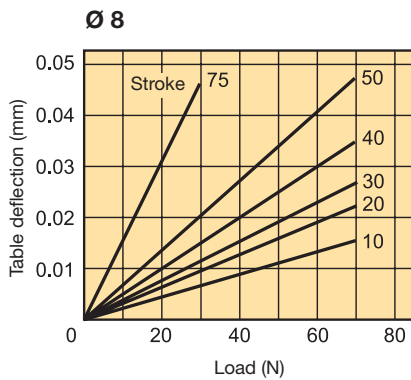
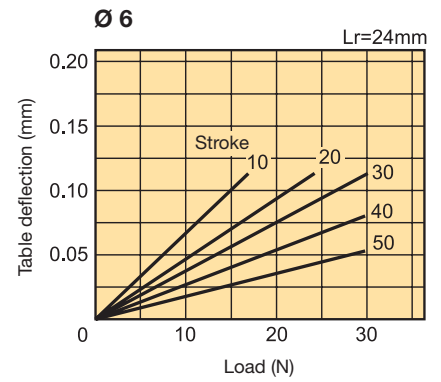
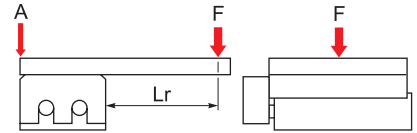
**Table deflection by yaw moment**

Table yaw deflection due to static yaw moment applied at arrow for fully extended stroke of slide table.



**Table deflection by roll moment**

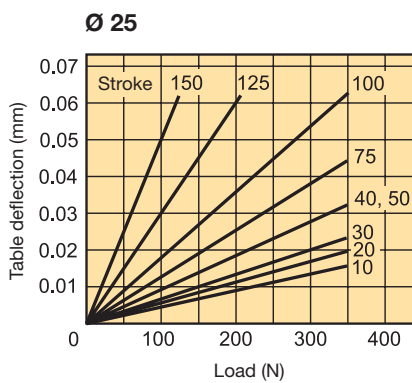
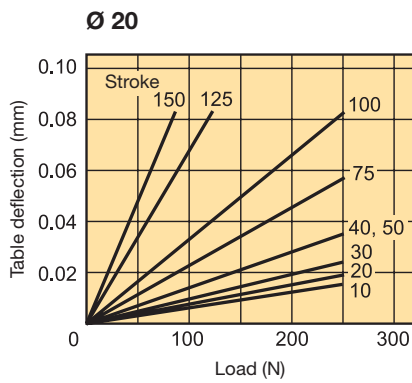
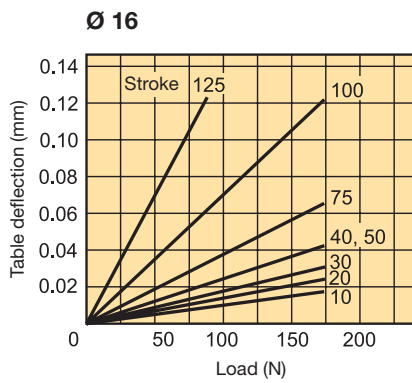
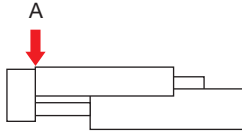
Table roll deflection arrow A due to static roll moment applied at arrow F when Lr = (see table) and table retracted.



**Table deflection**

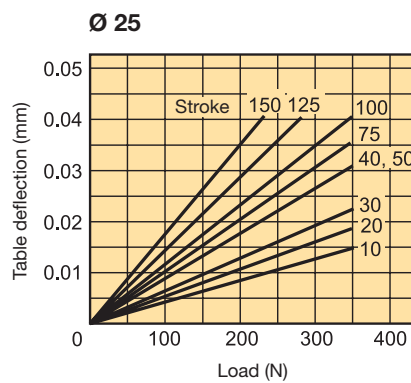
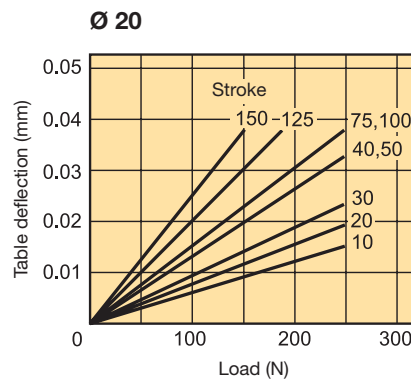
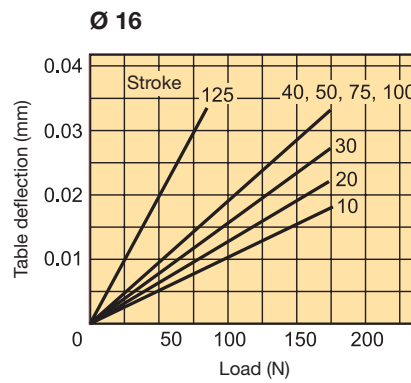
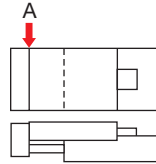
**Table deflection by pitch moment**

Table pitch deflection due to static pitch moment applied at arrow for fully extended stroke of slide table.



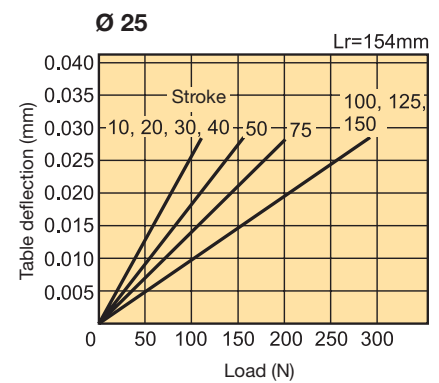
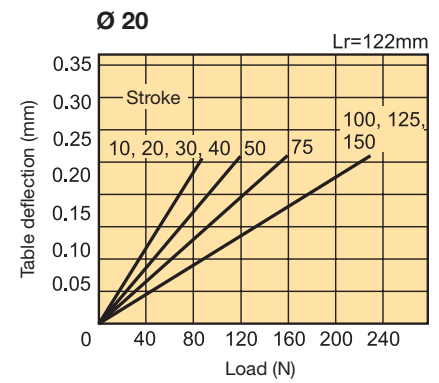
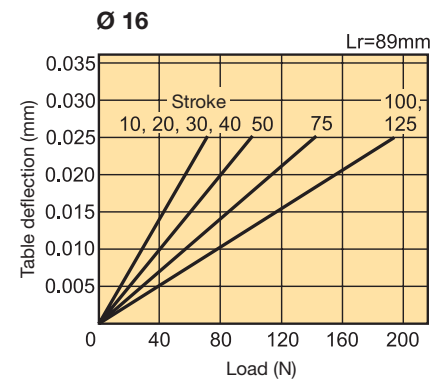
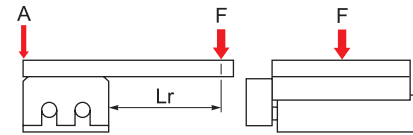
**Table deflection by yaw moment**

Table yaw deflection due to static yaw moment applied at arrow for fully extended stroke of slide table.

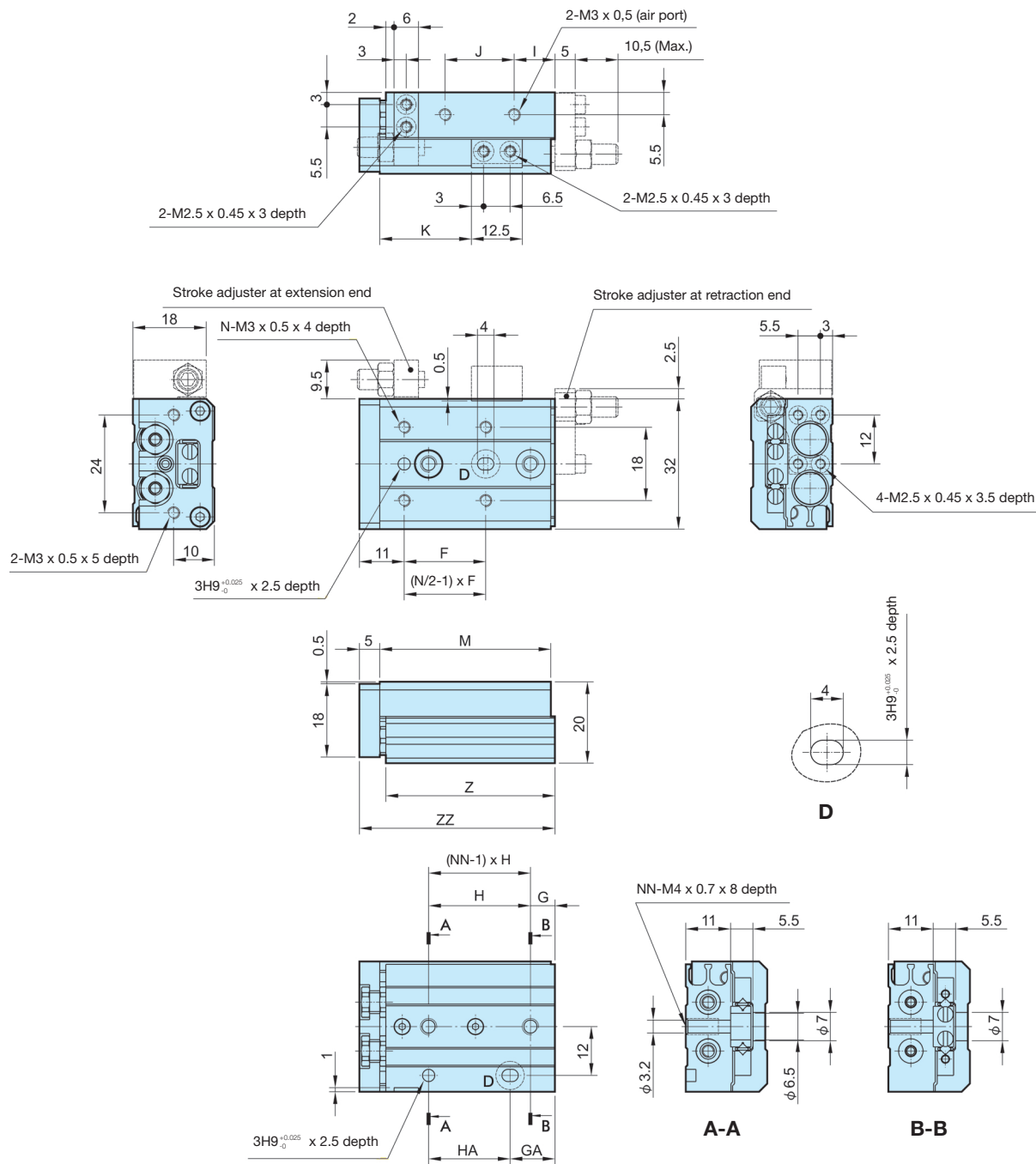


**Table deflection by roll moment**

Table roll deflection arrow A due to static roll moment applied at arrow F when Lr = (see table) and table retracted.

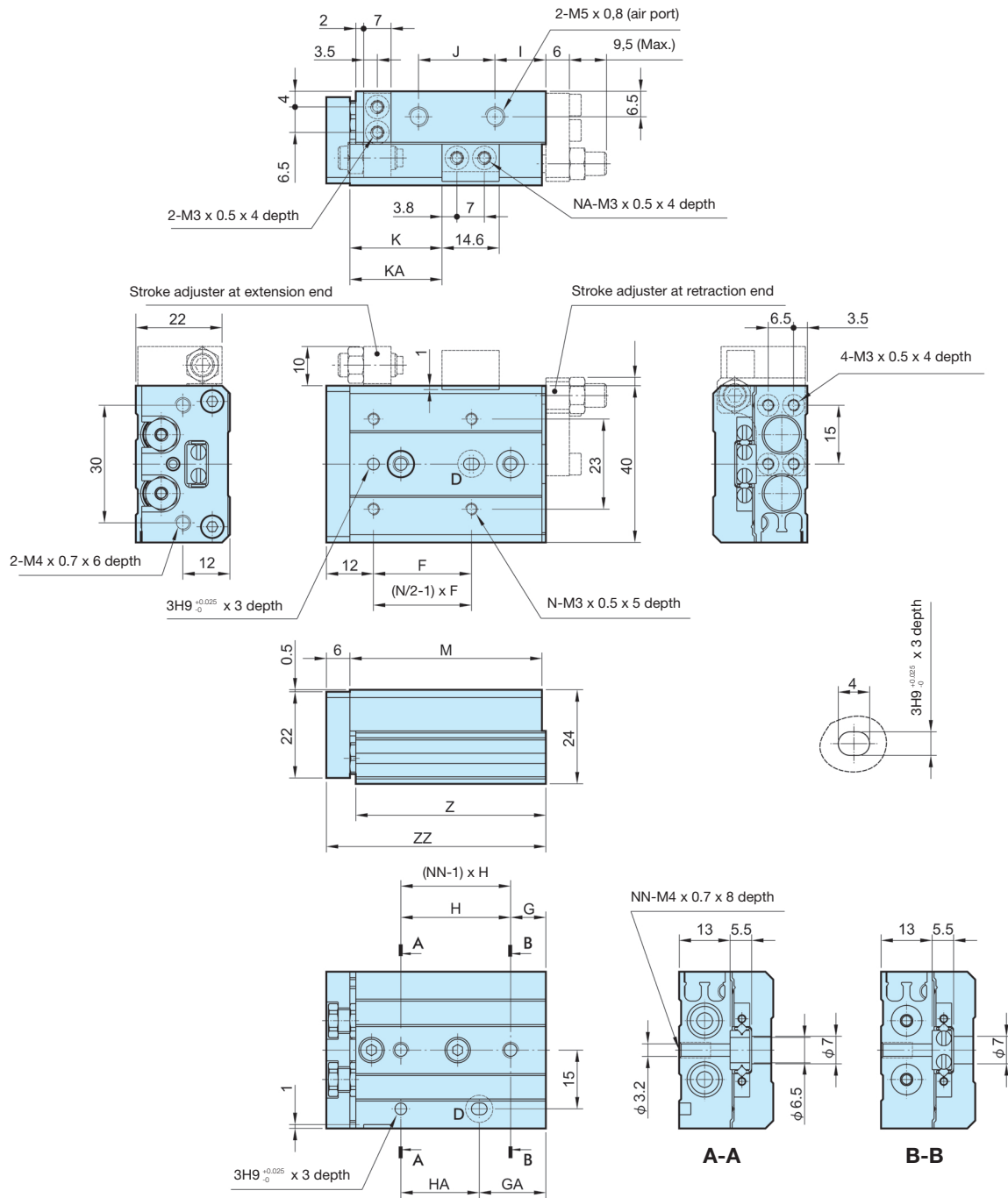


**Slide Table Ø6 - Dimensions (mm)**



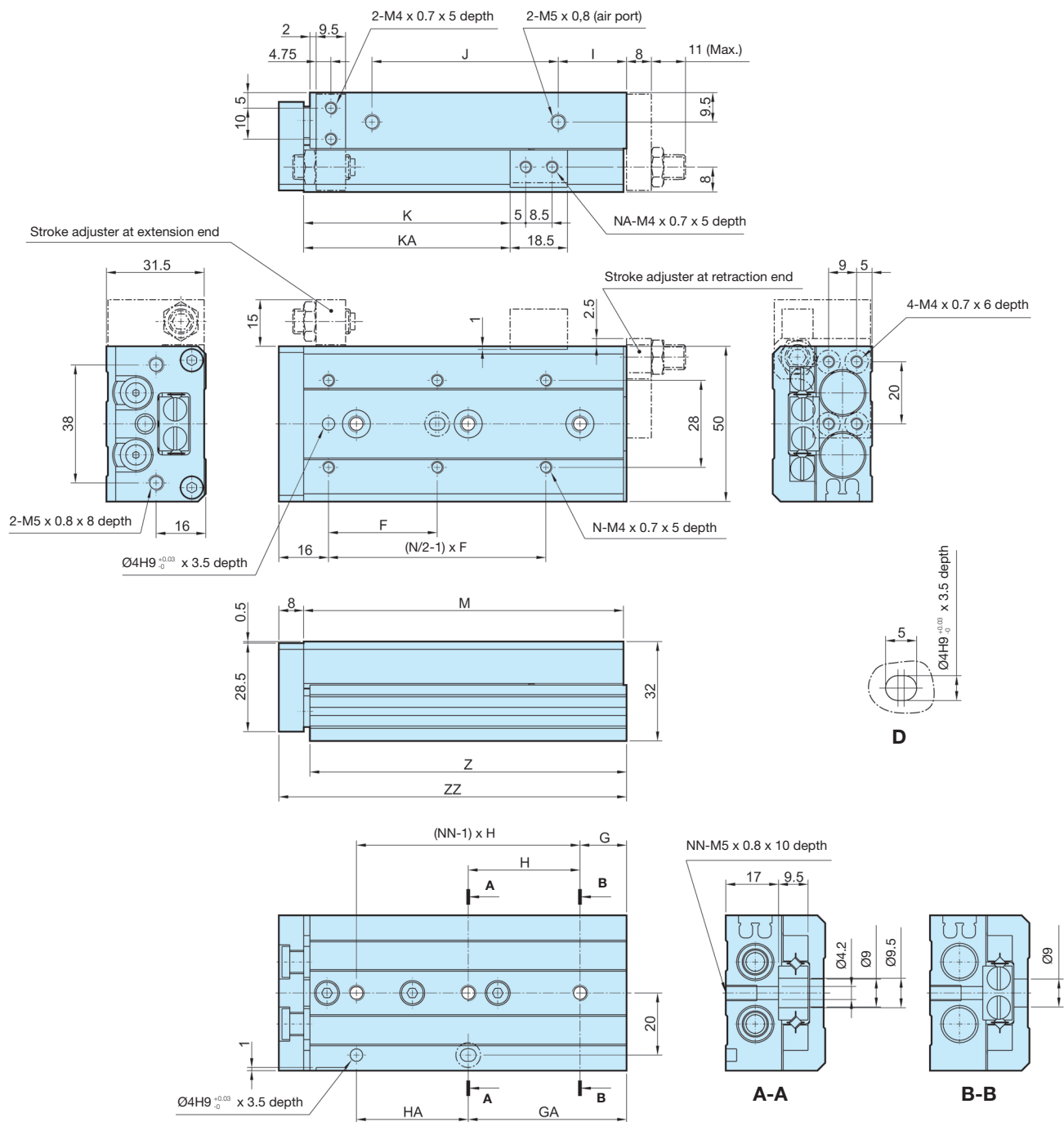
| Stroke | F  | G  | GA | H  | HA | I  | J  | K    | M   | N | NN | Z    | ZZ  |
|--------|----|----|----|----|----|----|----|------|-----|---|----|------|-----|
| 10     | 20 | 6  | 11 | 25 | 20 | 10 | 17 | 22,5 | 42  | 4 | 2  | 41,5 | 48  |
| 20     | 30 | 6  | 21 | 35 | 20 | 10 | 27 | 32,5 | 52  | 4 | 2  | 51,5 | 58  |
| 30     | 20 | 11 | 31 | 20 | 20 | 7  | 40 | 42,5 | 62  | 6 | 3  | 61,5 | 68  |
| 40     | 28 | 13 | 43 | 30 | 30 | 19 | 50 | 52,5 | 84  | 6 | 3  | 83,5 | 90  |
| 50     | 38 | 17 | 41 | 24 | 48 | 25 | 60 | 62,5 | 100 | 6 | 4  | 99,5 | 106 |

**Slide Table Ø8 - Dimensions (mm)**



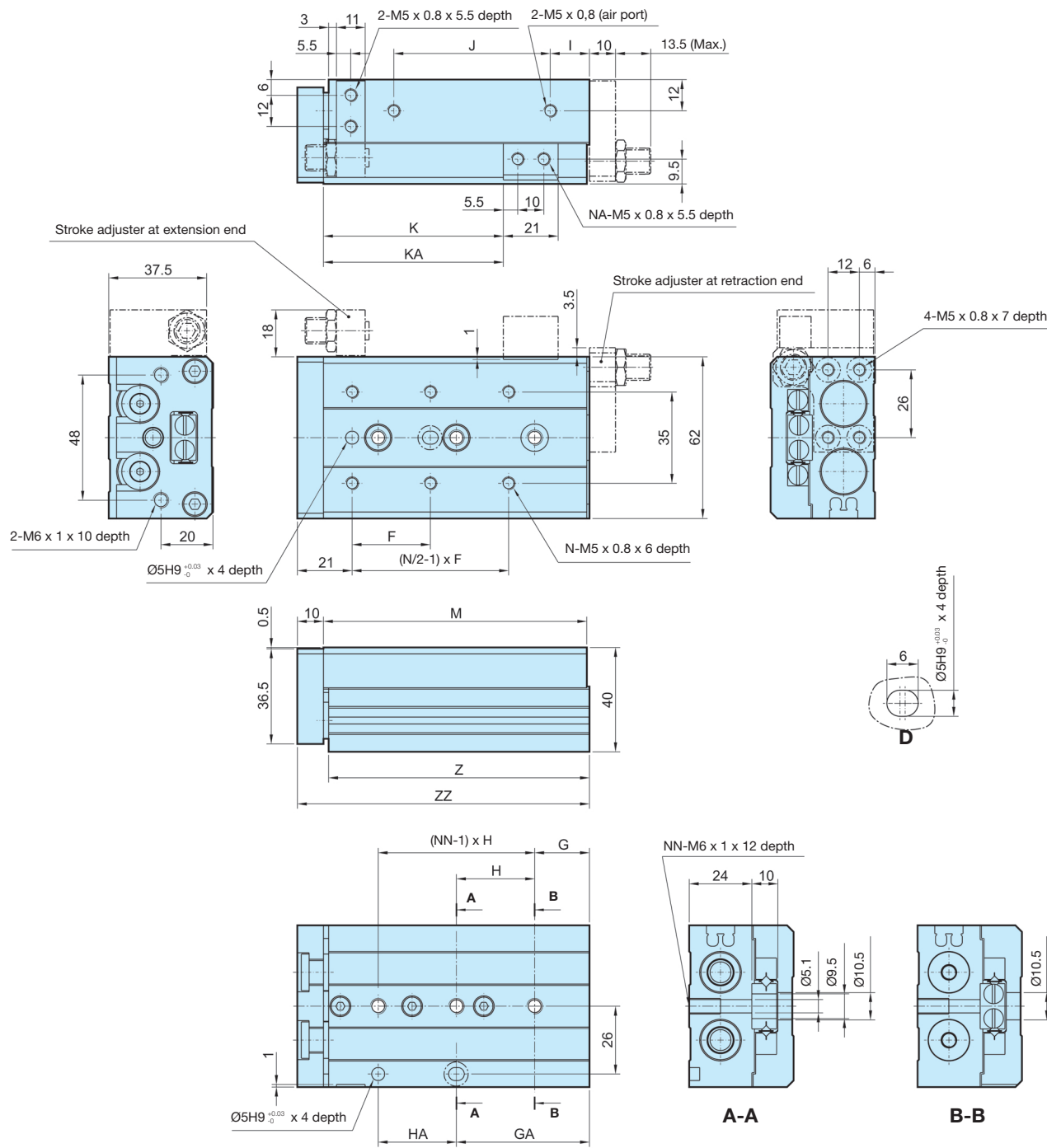
| Stroke | F  | G  | GA | H  | HA | I    | J    | K    | KA    | M   | N | NA | NN | Z     | ZZ  |
|--------|----|----|----|----|----|------|------|------|-------|-----|---|----|----|-------|-----|
| 10     | 25 | 9  | 17 | 28 | 20 | 13   | 19,5 | 23,5 | -     | 49  | 4 | 2  | 2  | 48,5  | 56  |
| 20     | 25 | 12 | 12 | 30 | 30 | 8,5  | 29   | 33,5 | -     | 54  | 4 | 2  | 2  | 53,5  | 61  |
| 30     | 40 | 13 | 33 | 20 | 20 | 9,5  | 39   | 43,5 | -     | 65  | 4 | 2  | 3  | 64,5  | 72  |
| 40     | 50 | 15 | 43 | 28 | 28 | 10,5 | 56   | 53,5 | -     | 83  | 4 | 2  | 3  | 82,5  | 90  |
| 50     | 38 | 20 | 43 | 23 | 46 | 24,5 | 60   | 63,5 | 82,5  | 101 | 6 | 4  | 4  | 100,5 | 108 |
| 75     | 50 | 27 | 83 | 28 | 56 | 38,5 | 96   | 88,5 | 132,5 | 151 | 6 | 4  | 5  | 150,5 | 158 |

**Slide Table Ø12 - Dimensions (mm)**



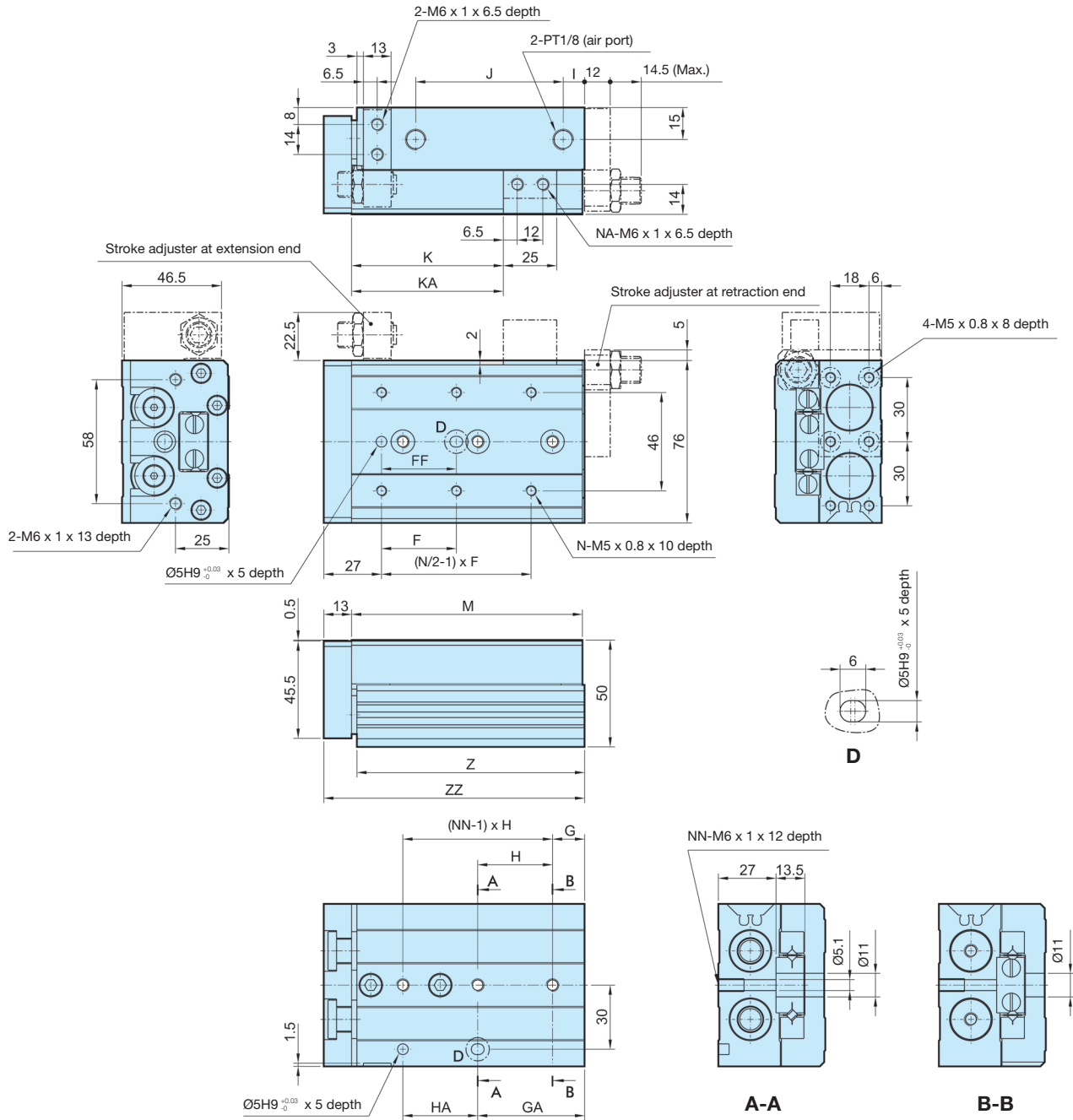
| Stroke | F  | G  | GA  | H  | HA | I  | J   | K     | KA    | M   | N | NA | NN | Z   | ZZ  |
|--------|----|----|-----|----|----|----|-----|-------|-------|-----|---|----|----|-----|-----|
| 10     | 35 | 15 | 15  | 40 | 40 | 10 | 40  | 26,5  | -     | 71  | 4 | 2  | 2  | 70  | 80  |
| 20     | 35 | 15 | 15  | 40 | 40 | 10 | 40  | 36,5  | -     | 71  | 4 | 2  | 2  | 70  | 80  |
| 30     | 35 | 15 | 15  | 40 | 40 | 10 | 40  | 46,5  | -     | 71  | 4 | 2  | 2  | 70  | 80  |
| 40     | 50 | 17 | 42  | 25 | 25 | 10 | 52  | 56,5  | -     | 83  | 4 | 2  | 3  | 82  | 92  |
| 50     | 35 | 15 | 51  | 36 | 36 | 22 | 60  | 66,5  | -     | 103 | 6 | 2  | 3  | 102 | 112 |
| 75     | 55 | 25 | 61  | 36 | 72 | 43 | 85  | 91,5  | 125,5 | 149 | 6 | 4  | 4  | 148 | 158 |
| 100    | 65 | 35 | 111 | 38 | 76 | 52 | 130 | 116,5 | 179,5 | 203 | 6 | 4  | 5  | 202 | 212 |

**Slide Table Ø16 - Dimensions (mm)**



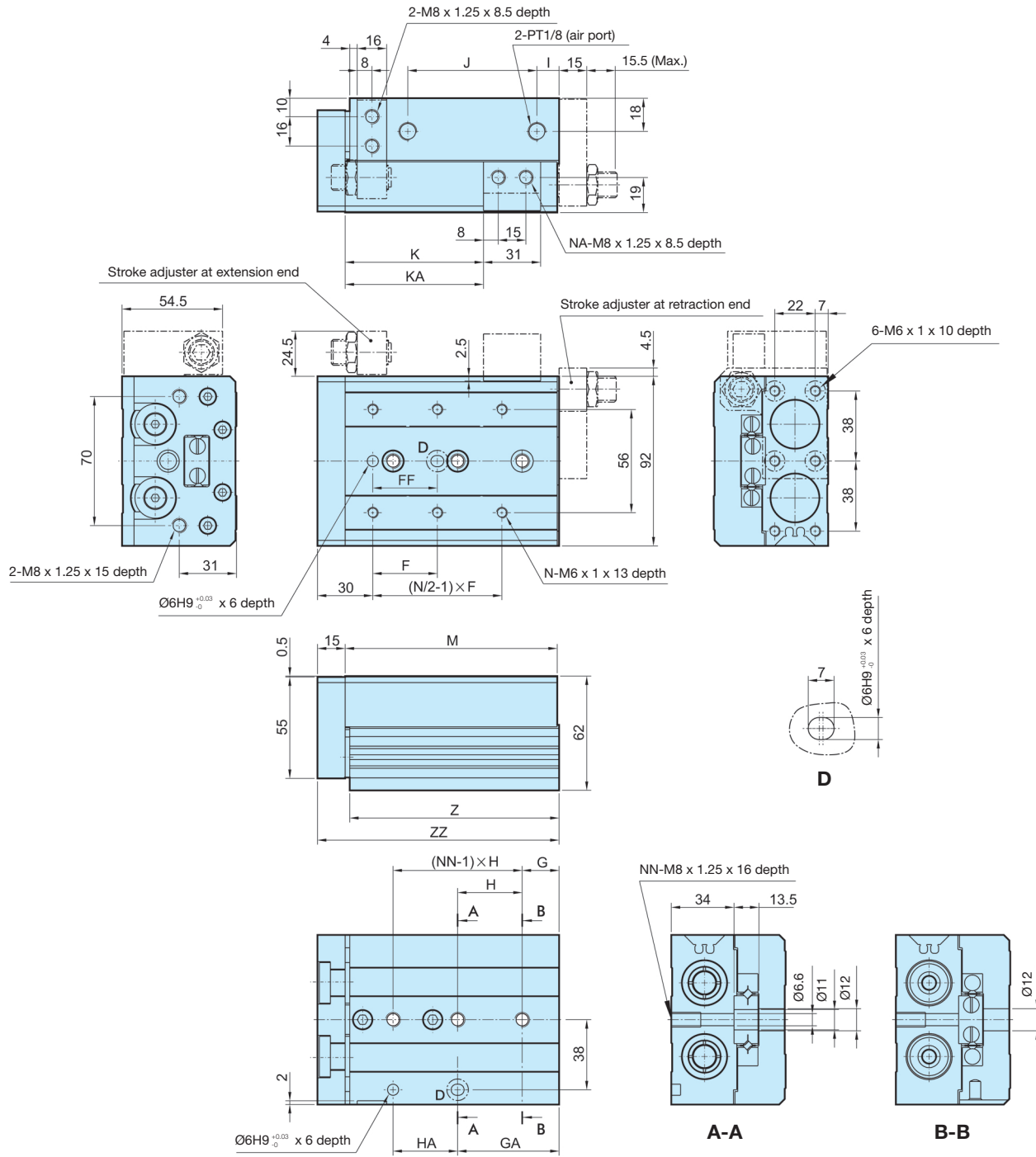
| Stroke | F  | G  | GA  | H  | HA | I  | J   | K   | KA  | M   | N | NA | NN | Z   | ZZ  |
|--------|----|----|-----|----|----|----|-----|-----|-----|-----|---|----|----|-----|-----|
| 10     | 35 | 16 | 16  | 40 | 40 | 10 | 40  | 29  | -   | 76  | 4 | 2  | 2  | 75  | 87  |
| 20     | 35 | 16 | 16  | 40 | 40 | 10 | 40  | 39  | -   | 76  | 4 | 2  | 2  | 75  | 87  |
| 30     | 35 | 16 | 16  | 40 | 40 | 10 | 40  | 49  | -   | 76  | 4 | 2  | 2  | 75  | 87  |
| 40     | 40 | 16 | 16  | 50 | 50 | 10 | 50  | 59  | -   | 86  | 4 | 2  | 2  | 85  | 97  |
| 50     | 30 | 21 | 51  | 30 | 30 | 15 | 60  | 69  | -   | 101 | 6 | 2  | 3  | 100 | 112 |
| 75     | 55 | 26 | 61  | 35 | 70 | 40 | 85  | 94  | 125 | 151 | 6 | 4  | 4  | 150 | 162 |
| 100    | 65 | 39 | 109 | 35 | 70 | 55 | 118 | 119 | 173 | 199 | 6 | 4  | 5  | 198 | 210 |
| 125    | 70 | 19 | 159 | 35 | 70 | 68 | 155 | 144 | 223 | 249 | 8 | 4  | 7  | 248 | 260 |

**Slide Table Ø20 - Dimensions (mm)**



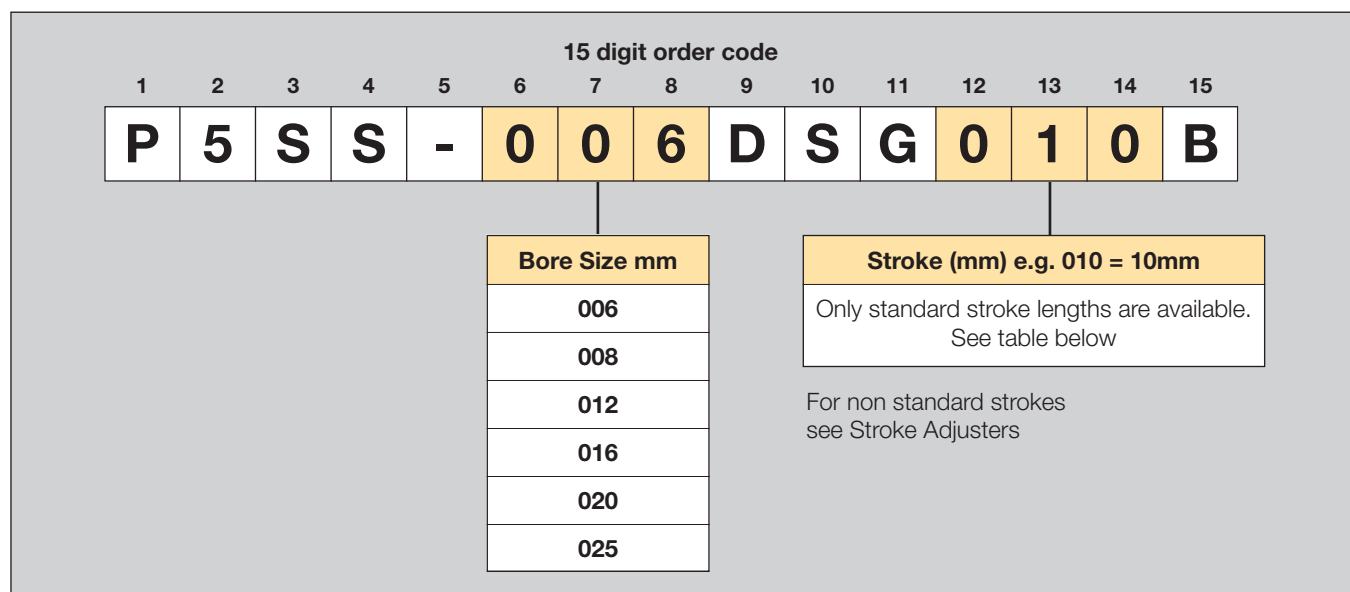
| Stroke | F  | FF | G  | GA  | H  | HA | I  | J   | K   | KA  | M   | N | NA | NN | Z     | ZZ  |
|--------|----|----|----|-----|----|----|----|-----|-----|-----|-----|---|----|----|-------|-----|
| 10     | 50 | 40 | 15 | 25  | 45 | 35 | 10 | 44  | 31  | -   | 83  | 4 | 2  | 2  | 81,5  | 97  |
| 20     | 50 | 40 | 15 | 25  | 45 | 35 | 10 | 44  | 41  | -   | 83  | 4 | 2  | 2  | 81,5  | 97  |
| 30     | 50 | 40 | 15 | 25  | 45 | 35 | 10 | 44  | 51  | -   | 83  | 4 | 2  | 2  | 81,5  | 97  |
| 40     | 60 | 50 | 15 | 35  | 55 | 35 | 10 | 54  | 61  | -   | 93  | 4 | 2  | 2  | 91,5  | 107 |
| 50     | 35 | 35 | 15 | 50  | 35 | 35 | 10 | 69  | 71  | -   | 108 | 6 | 2  | 3  | 106,5 | 122 |
| 75     | 60 | 60 | 19 | 54  | 35 | 70 | 10 | 108 | 96  | -   | 147 | 6 | 2  | 4  | 145,5 | 161 |
| 100    | 70 | 70 | 37 | 107 | 35 | 70 | 58 | 113 | 121 | 169 | 200 | 6 | 4  | 5  | 198,5 | 214 |
| 125    | 70 | 70 | 41 | 155 | 38 | 76 | 70 | 155 | 146 | 223 | 254 | 8 | 4  | 6  | 252,5 | 268 |
| 150    | 80 | 80 | 19 | 195 | 44 | 88 | 87 | 190 | 171 | 275 | 306 | 8 | 4  | 7  | 304,5 | 320 |

**Slide Table Ø25 - Dimensions (mm)**



| Stroke | F  | FF | G  | GA  | H  | HA | I  | J   | K   | KA  | M   | N | NA | NN | Z     | ZZ  |
|--------|----|----|----|-----|----|----|----|-----|-----|-----|-----|---|----|----|-------|-----|
| 10     | 50 | 40 | 22 | 22  | 45 | 45 | 12 | 47  | 35  | -   | 92  | 4 | 2  | 2  | 90,5  | 108 |
| 20     | 50 | 40 | 22 | 22  | 45 | 45 | 12 | 47  | 45  | -   | 92  | 4 | 2  | 2  | 90,5  | 108 |
| 30     | 50 | 40 | 22 | 22  | 45 | 45 | 12 | 47  | 55  | -   | 92  | 4 | 2  | 2  | 90,5  | 108 |
| 40     | 60 | 50 | 22 | 22  | 55 | 55 | 12 | 57  | 65  | -   | 102 | 4 | 2  | 2  | 100,5 | 118 |
| 50     | 35 | 35 | 20 | 55  | 35 | 35 | 12 | 70  | 75  | -   | 115 | 6 | 2  | 3  | 113,5 | 131 |
| 75     | 60 | 60 | 26 | 61  | 35 | 70 | 33 | 90  | 100 | -   | 156 | 6 | 2  | 4  | 154,5 | 172 |
| 100    | 70 | 70 | 32 | 102 | 35 | 70 | 50 | 114 | 125 | 162 | 197 | 6 | 4  | 5  | 195,5 | 213 |
| 125    | 75 | 75 | 40 | 154 | 38 | 76 | 67 | 155 | 150 | 218 | 255 | 8 | 4  | 6  | 253,5 | 271 |
| 150    | 80 | 80 | 30 | 190 | 40 | 80 | 82 | 180 | 175 | 258 | 295 | 8 | 4  | 7  | 293,5 | 311 |

**Order Key Code**



**Note :** All slides are supplied magnetic for optional sensing

**Standard strokes**

| Order code      | Cylinder bore (mm) | ● = Standard stroke (mm) |    |    |    |    |    |     |     |     |  |
|-----------------|--------------------|--------------------------|----|----|----|----|----|-----|-----|-----|--|
| XXX = stroke    |                    | 10                       | 20 | 30 | 40 | 50 | 75 | 100 | 125 | 150 |  |
| P5SS-006DSGXXXB | 6                  | ●                        | ●  | ●  | ●  | ●  |    |     |     |     |  |
| P5SS-008DSGXXXB | 8                  | ●                        | ●  | ●  | ●  | ●  | ●  |     |     |     |  |
| P5SS-012DSGXXXB | 12                 | ●                        | ●  | ●  | ●  | ●  | ●  | ●   |     |     |  |
| P5SS-016DSGXXXB | 16                 | ●                        | ●  | ●  | ●  | ●  | ●  | ●   | ●   |     |  |
| P5SS-020DSGXXXB | 20                 | ●                        | ●  | ●  | ●  | ●  | ●  | ●   | ●   | ●   |  |
| P5SS-025DSGXXXB | 25                 | ●                        | ●  | ●  | ●  | ●  | ●  | ●   | ●   | ●   |  |

**Note:** Only strokes listed above are available.  
 For optional stroke adjusters see next page.

**Ordering Information: P5SS**

**Ø6mm bore**

| Stroke (mm) | Order code      |
|-------------|-----------------|
| 10          | P5SS-006DSG010B |
| 20          | P5SS-006DSG020B |
| 30          | P5SS-006DSG030B |
| 40          | P5SS-006DSG040B |
| 50          | P5SS-006DSG050B |

**Ø12mm bore**

| Stroke (mm) | Order code      |
|-------------|-----------------|
| 10          | P5SS-012DSG010B |
| 20          | P5SS-012DSG020B |
| 30          | P5SS-012DSG030B |
| 40          | P5SS-012DSG040B |
| 50          | P5SS-012DSG050B |
| 75          | P5SS-012DSG075B |
| 100         | P5SS-012DSG100B |

**Ø20mm bore**

| Stroke (mm) | Order code      |
|-------------|-----------------|
| 10          | P5SS-020DSG010B |
| 20          | P5SS-020DSG020B |
| 30          | P5SS-020DSG030B |
| 40          | P5SS-020DSG040B |
| 50          | P5SS-020DSG050B |
| 75          | P5SS-020DSG075B |
| 100         | P5SS-020DSG100B |
| 125         | P5SS-020DSG125B |
| 150         | P5SS-020DSG150B |

**Ø8mm bore**

| Stroke (mm) | Order code      |
|-------------|-----------------|
| 10          | P5SS-008DSG010B |
| 20          | P5SS-008DSG020B |
| 30          | P5SS-008DSG030B |
| 40          | P5SS-008DSG040B |
| 50          | P5SS-008DSG050B |
| 75          | P5SS-008DSG075B |

**Ø16mm bore**

| Stroke (mm) | Order code      |
|-------------|-----------------|
| 10          | P5SS-016DSG010B |
| 20          | P5SS-016DSG020B |
| 30          | P5SS-016DSG030B |
| 40          | P5SS-016DSG040B |
| 50          | P5SS-016DSG050B |
| 75          | P5SS-016DSG075B |
| 100         | P5SS-016DSG100B |
| 125         | P5SS-016DSG125B |

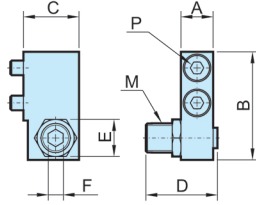
**Ø25mm bore**

| Stroke (mm) | Order code      |
|-------------|-----------------|
| 10          | P5SS-025DSG010B |
| 20          | P5SS-025DSG020B |
| 30          | P5SS-025DSG030B |
| 40          | P5SS-025DSG040B |
| 50          | P5SS-025DSG050B |
| 75          | P5SS-025DSG075B |
| 100         | P5SS-025DSG100B |
| 125         | P5SS-025DSG125B |
| 150         | P5SS-025DSG150B |

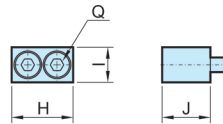
**Accessories Ø 6 - Ø 25**

**Stroke adjuster at extension end:**

Mounted to body



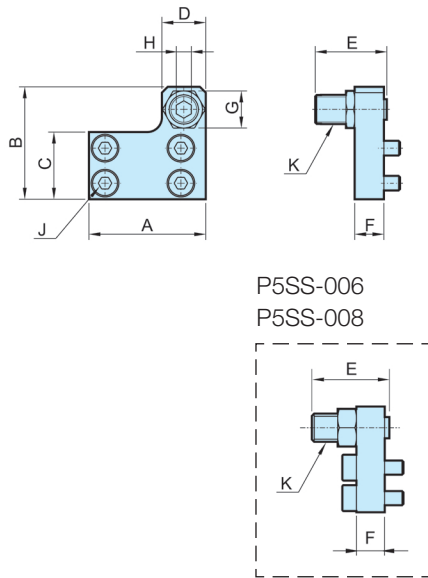
Mounted to table



| Bore mm | Order code     | Adjustable stroke range (mm) | Mounted to body |      |      |      |    |     |            | Mounted to table |      |    |      |          |
|---------|----------------|------------------------------|-----------------|------|------|------|----|-----|------------|------------------|------|----|------|----------|
|         |                |                              | A               | B    | C    | D    | E  | F   | M          | P*               | H    | I  | J    | Q*       |
| 6       | P5SS-006-EA-05 | 5                            | 6               | 17,8 | 10,5 | 16,5 | 7  | 2,5 | M5 x 0.8   | M2.5x10          | 12,5 | 6  | 8,5  | M2.5 x 8 |
|         | P5SS-006-EA-15 | 15                           |                 |      |      | 26,5 |    |     |            |                  |      |    |      |          |
| 8       | P5SS-008-EA-05 | 5                            |                 |      |      | 16,5 |    |     |            |                  |      |    |      |          |
|         | P5SS-008-EA-15 | 15                           | 7               | 21,5 | 11   | 26,5 | 8  | 3   | M6 x 1     | M3 x 10          | 14,6 | 7  | 10   | M3 x 10  |
|         | P5SS-008-EA-25 | 25                           |                 |      |      | 36,5 |    |     |            |                  |      |    |      |          |
| 12      | P5SS-012-EA-05 | 5                            |                 |      |      | 20   |    |     |            |                  |      |    |      |          |
|         | P5SS-012-EA-15 | 15                           | 9,5             | 31   | 16   | 30   | 11 | 4   | M8 x 1     | M4 x 16          | 18,5 | 10 | 13   | M4 x 12  |
|         | P5SS-012-EA-25 | 25                           |                 |      |      | 40   |    |     |            |                  |      |    |      |          |
| 16      | P5SS-016-EA-05 | 5                            |                 |      |      | 24,5 |    |     |            |                  |      |    |      |          |
|         | P5SS-016-EA-15 | 15                           | 11              | 37   | 19   | 34,5 | 14 | 5   | M10 x 1    | M5 x 16          | 21   | 12 | 16,5 | M5 x 16  |
|         | P5SS-016-EA-25 | 25                           |                 |      |      | 44,5 |    |     |            |                  |      |    |      |          |
| 20      | P5SS-020-EA-05 | 5                            |                 |      |      | 27,5 |    |     |            |                  |      |    |      |          |
|         | P5SS-020-EA-15 | 15                           | 13              | 45,5 | 24   | 37,5 | 17 | 6   | M12 x 1.25 | M6 x 20          | 25   | 13 | 21   | M6 x 20  |
|         | P5SS-020-EA-25 | 25                           |                 |      |      | 47,5 |    |     |            |                  |      |    |      |          |
| 25      | P5SS-025-EA-05 | 5                            |                 |      |      | 32,5 |    |     |            |                  |      |    |      |          |
|         | P5SS-025-EA-15 | 15                           | 16              | 53,5 | 26,5 | 42,5 | 19 | 6   | M14 x 1.5  | M8 x 25          | 31   | 17 | 25,5 | M8 x 25  |
|         | P5SS-025-EA-25 | 25                           |                 |      |      | 52,5 |    |     |            |                  |      |    |      |          |

\* Size of hexagon socket head cap screws

**Stroke adjuster at retraction end:**

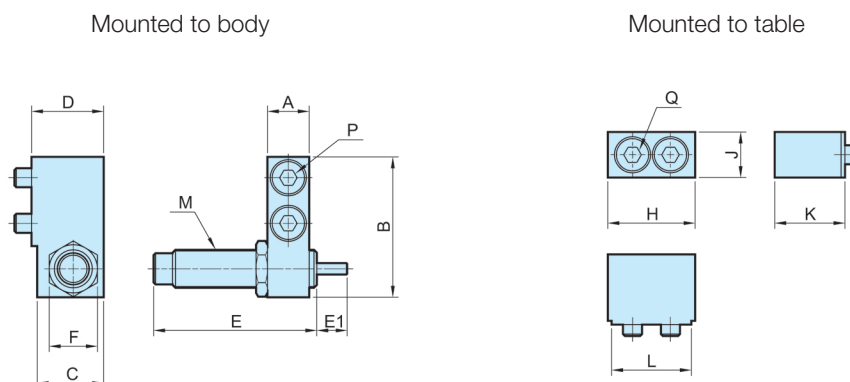


| Bore mm | Order code     | Adjustable stroke range (mm) | A  | B    | C    | D    | E    | F  | G  | H   | J*       | K          |
|---------|----------------|------------------------------|----|------|------|------|------|----|----|-----|----------|------------|
|         |                |                              |    |      |      |      |      |    |    |     |          |            |
| 6       | P5SS-006-RA-05 | 5                            | 21 | 19   | 10,5 | 8    | 16,5 | 5  | 7  | 2,5 | M2.5 x 8 | M5 x 0.8   |
|         | P5SS-006-RA-15 | 15                           |    |      |      | 26,5 |      |    |    |     |          |            |
| 8       | P5SS-008-RA-05 | 5                            |    |      |      | 16,5 |      |    |    |     |          |            |
|         | P5SS-008-RA-15 | 15                           | 25 | 22,5 | 12,5 | 9    | 26,5 | 6  | 8  | 3   | M3 x 10  | M6 x 1     |
|         | P5SS-008-RA-25 | 25                           |    |      |      | 36,5 |      |    |    |     |          |            |
| 12      | P5SS-012-RA-05 | 5                            |    |      |      | 20   |      |    |    |     |          |            |
|         | P5SS-012-RA-15 | 15                           | 32 | 31   | 18,5 | 13   | 30   | 8  | 12 | 4   | M4 x 8   | M8 x 1     |
|         | P5SS-012-RA-25 | 25                           |    |      |      | 40   |      |    |    |     |          |            |
| 16      | P5SS-016-RA-05 | 5                            |    |      |      | 24,5 |      |    |    |     |          |            |
|         | P5SS-016-RA-15 | 15                           | 40 | 38,5 | 23   | 15   | 34,5 | 10 | 14 | 5   | M5 x 10  | M10 x 1    |
|         | P5SS-016-RA-25 | 25                           |    |      |      | 44,5 |      |    |    |     |          |            |
| 20      | P5SS-020-RA-05 | 5                            |    |      |      | 27,5 |      |    |    |     |          |            |
|         | P5SS-020-RA-15 | 15                           | 50 | 48   | 29   | 21   | 37,5 | 12 | 17 | 6   | M5 x 12  | M12 x 1.25 |
|         | P5SS-020-RA-25 | 25                           |    |      |      | 47,5 |      |    |    |     |          |            |
| 25      | P5SS-025-RA-05 | 5                            |    |      |      | 32,5 |      |    |    |     |          |            |
|         | P5SS-025-RA-15 | 15                           | 60 | 58   | 35   | 23   | 42,5 | 15 | 19 | 6   | M6 x 16  | M14 x 1.5  |
|         | P5SS-025-RA-25 | 25                           |    |      |      | 52,5 |      |    |    |     |          |            |

\* Size of hexagon socket head cap screws

**Accessories Ø 8 - Ø 25**

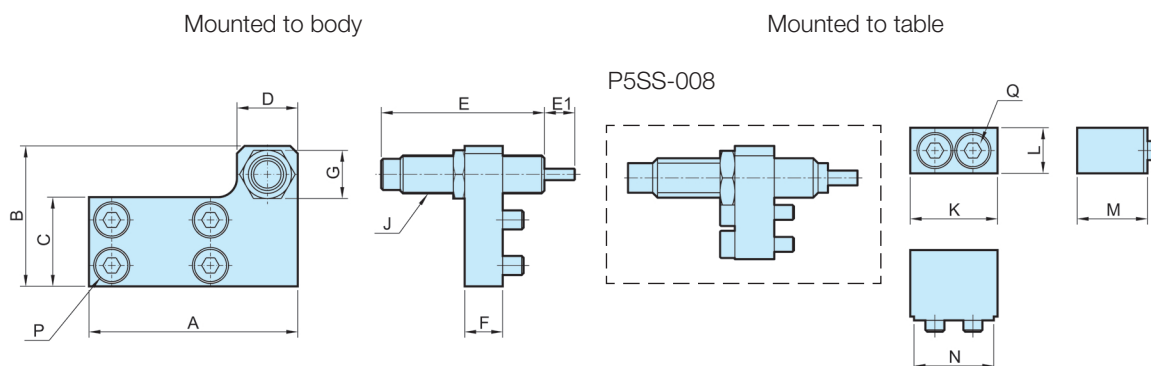
**Shock absorber at extension end:**



| Bore mm | Order code          | Mounted to body |      |      |      |      |    |      |           |         | Mounted to table |    |      |      |         |
|---------|---------------------|-----------------|------|------|------|------|----|------|-----------|---------|------------------|----|------|------|---------|
|         |                     | A               | B    | C    | D    | E    | E1 | F    | M         | P*      | H                | J  | K    | L    | Q*      |
| 8       | <b>P5SS-008-ESK</b> | 7               | 23   | 14   | 15,5 | 40,6 | 6  | 11   | M8 x 1    | M3 x 16 | 16,6             | 7  | 15,5 | 14,6 | M3 x 16 |
| 12      | <b>P5SS-012-ESK</b> | 9,5             | 31   | 14,5 | 16   | 40,6 | 6  | 11   | M8 x 1    | M4 x 16 | 20,5             | 10 | 15   | 18,5 | M4 x 12 |
| 16      | <b>P5SS-016-ESK</b> | 11              | 37   | 17,5 | 19   | 47   | 7  | 12,7 | M10 x 1   | M5 x 16 | 23               | 12 | 18,5 | 21   | M5 x 16 |
| 20      | <b>P5SS-020-ESK</b> | 13              | 45,5 | 23,5 | 26   | 67   | 12 | 19   | M14 x 1.5 | M6 x 25 | 27               | 13 | 25,5 | 25   | M6 x 25 |
| 25      | <b>P5SS-025-ESK</b> | 16              | 53,5 | 23,5 | 26,5 | 67   | 12 | 19   | M14 x 1.5 | M8 x 25 | 33               | 17 | 25,5 | 31   | M8 x 25 |

\* Size of hexagon socket head cap screws

**Shock absorber at retraction end:**



| Bore mm | Order code          | Mounted to body |    |      |    |      |    |    |      |           |         | Mounted to table |    |      |      |         |
|---------|---------------------|-----------------|----|------|----|------|----|----|------|-----------|---------|------------------|----|------|------|---------|
|         |                     | A               | B  | C    | D  | E    | E1 | F  | G    | J         | P*      | K                | L  | M    | N    | Q*      |
| 8       | <b>P5SS-008-RSK</b> | 38              | 23 | 12,5 | 14 | 40,6 | 6  | 8  | 12   | M8 x 1    | M3 x 12 | 16,6             | 7  | 15,5 | 14,6 | M3 x 16 |
| 12      | <b>P5SS-012-RSK</b> | 45              | 31 | 18   | 14 | 40,6 | 6  | 8  | 11   | M8 x 1    | M4 x 8  | 20,5             | 10 | 15   | 18,5 | M4 x 12 |
| 16      | <b>P5SS-016-RSK</b> | 55              | 37 | 23,5 | 16 | 47   | 7  | 10 | 12,7 | M10 x 1   | M5 x 10 | 23               | 12 | 18,5 | 21   | M5 x 16 |
| 20      | <b>P5SS-020-RSK</b> | 70              | 47 | 29   | 23 | 67   | 12 | 12 | 19   | M14 x 1.5 | M5 x 12 | 27               | 13 | 25,5 | 25   | M6 x 25 |
| 25      | <b>P5SS-025-RSK</b> | 80              | 54 | 35   | 23 | 67   | 12 | 12 | 19   | M14 x 1.5 | M6 x 16 | 33               | 17 | 25,5 | 31   | M8 x 25 |

\* Size of hexagon socket head cap screws



**Stroke Adjustment Bolts**

| Bore | Description          | Order code            |
|------|----------------------|-----------------------|
| 6    | 5mm Adjustment bolt  | <b>P5SS-006-SA-05</b> |
|      | 15mm Adjustment bolt | <b>P5SS-006-SA-15</b> |
| 8    | 5mm Adjustment bolt  | <b>P5SS-008-SA-05</b> |
|      | 15mm Adjustment bolt | <b>P5SS-008-SA-15</b> |
|      | 25mm Adjustment bolt | <b>P5SS-008-SA-25</b> |
| 12   | 5mm Adjustment bolt  | <b>P5SS-012-SA-05</b> |
|      | 15mm Adjustment bolt | <b>P5SS-012-SA-15</b> |
|      | 25mm Adjustment bolt | <b>P5SS-012-SA-25</b> |
| 16   | 5mm Adjustment bolt  | <b>P5SS-016-SA-05</b> |
|      | 15mm Adjustment bolt | <b>P5SS-016-SA-15</b> |
|      | 25mm Adjustment bolt | <b>P5SS-016-SA-25</b> |
| 20   | 5mm Adjustment bolt  | <b>P5SS-020-SA-05</b> |
|      | 15mm Adjustment bolt | <b>P5SS-020-SA-15</b> |
|      | 25mm Adjustment bolt | <b>P5SS-020-SA-25</b> |
| 25   | 5mm Adjustment bolt  | <b>P5SS-025-SA-05</b> |
|      | 15mm Adjustment bolt | <b>P5SS-025-SA-15</b> |
|      | 25mm Adjustment bolt | <b>P5SS-025-SA-25</b> |

**Optional Shock Absorbers**

| Bore | Rotary Actuator | Order code        |
|------|-----------------|-------------------|
| 6    | P5SS-006MSGXXB  | Not applicable    |
| 8    | P5SS-008MSGXXB  | <b>MC10EUML</b>   |
| 12   | P5SS-012MSGXXB  | <b>MC10EUML</b>   |
| 16   | P5SS-016MSGXXB  | <b>MC25EUM-NB</b> |
| 20   | P5SS-020MSGXXB  | <b>MC150M</b>     |
| 25   | P5SS-025MSGXXB  | <b>MC150M</b>     |

## P8S Sensors Series

The P8S family of sensors provides a broad range of reed and solid state sensor types with flying lead or M8 options available. Mounting on all slides is within the integrated sensor grooves allowing for compact installation.

### Electronic sensors

The electronic sensors utilise “Solid State” technology, providing operation with no moving parts. These switches are available in NPN and PNP type, both provide built in short circuit and transient protection as standard. The solid state operation allows for high switching on off frequency, ideal for applications where long service life is required.

#### Technical data

|                            |   |
|----------------------------|---|
| Design                     | GMR (Giant Magnetic Resistance)<br>magneto-resistive function |
| Installation               | Mounts within cylinder switch groove                          |
| Outputs                    | PNP or NPN normally open                                      |
| Voltage range              | 5-30 V DC   |
| Voltage drop               | 1.5 V max.  |
| Switching current          | 50 mA max.  |
| Switch rating              | 1.5 W max.  |
| Leakage current            | 0.01 mA max.  |
| Internal consumption       | 10 mA max (NPN)<br>12 mA max (PNP)                            |
| On/off switching frequency | 1000 Hz max   |
| Encapsulation              | IP 67 (NEMA 6)  |
| Temperature range          | -10 °C to +70 °C  |
| Indication                 | LED Red (NPN)<br>LED Green (PNP)                              |
| Cable                      | Polyurethane  |

### Reed sensors

Reed type sensors are based on proven reed switch technology and provide reliable function in many applications. Simple installation and the available AC voltage range are advantages for this range of sensors.

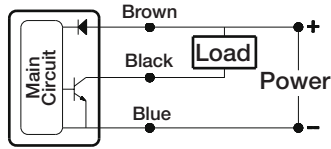
#### Technical data

|                   |                                      |
|-------------------|--------------------------------------|
| Design            | Reed element                         |
| Installation      | Mounts within cylinder switch groove |
| Outputs           | Normally open                        |
| Voltage range     | 5-120 V DC/AC                        |
| Voltage drop      | 2.5 V max.                           |
| Switching current | 100 mA max.                          |
| Switch rating     | 10 W max.                            |
| Encapsulation     | IP 67 (NEMA 6)                       |
| Temperature range | -10 °C to +70 °C                     |
| Indication        | LED Red (NPN)                        |
| Cable             | Polyurethane                         |

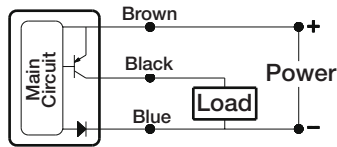
**Electronic sensors**

**Schematic**

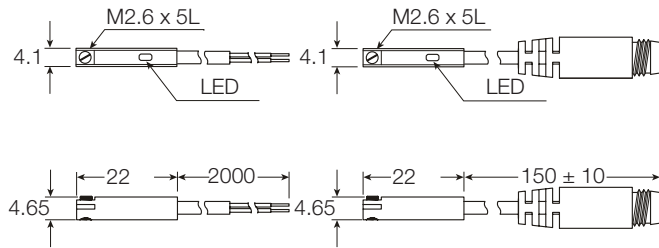
**NPN type**



**PNP type**



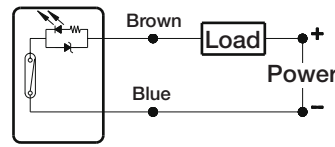
**Dimensions**



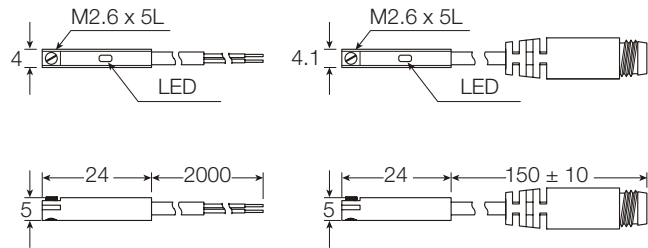
**Reed sensors**

**Schematic**

**Reed type**

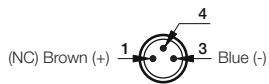


**Dimensions**

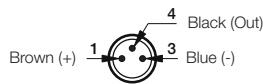


**M8 Quick Connector**

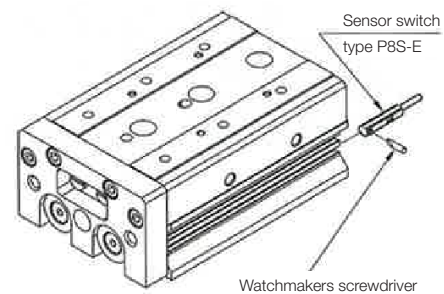
**2 wire**



**3 wire**



**Installation of Sensor**



**Electronic and Reed Sensors**

| Size                     | Description                               | Order code       |
|--------------------------|---|------------------|
| <b>Flush Mount Style</b> |   |                  |
| PNP Type, normally open  | 0.165 m cable and M8 screw male connector | <b>P8S-EPSUS</b> |
| PNP Type, normally open  | 2 m PUR cable without connector           | <b>P8S-EPFXS</b> |
| NPN Type, normally open  | 0.165 m cable and M8 screw male connector | <b>P8S-ENSUS</b> |
| NPN Type, normally open  | 2 m PUR cable without connector           | <b>P8S-ENFXS</b> |
| Reed Type, normally open | 0.15 m cable and M8 screw male connector  | <b>P8S-ERSUS</b> |
| Reed Type, normally open | 2 m PUR cable without connector           | <b>P8S-ERFXS</b> |

### Connecting cables with one connector

The cables have an integral snap-in female connector.



| Type of cable   | Cable/connector              | Weight<br>kg | Order code        |
|---|------------------------------|--------------|-------------------|
| <b>Cables for sensors, complete with one female connector</b> |                              |              |                   |
| Cable, Flex PVC   | 3 m, 8 mm Snap-in connector  | 0,07         | <b>9126344341</b> |
| Cable, Flex PVC   | 10 m, 8 mm Snap-in connector | 0,21         | <b>9126344342</b> |
| Cable, Super Flex PVC   | 3 m, 8 mm Snap-in connector  | 0,07         | <b>9126344343</b> |
| Cable, Super Flex PVC   | 10 m, 8 mm Snap-in connector | 0,21         | <b>9126344344</b> |
| Cable, Polyurethane   | 3 m, 8 mm Snap-in connector  | 0,01         | <b>9126344345</b> |
| Cable, Polyurethane   | 10 m, 8 mm Snap-in connector | 0,20         | <b>9126344346</b> |

### Male connectors for connecting cables

Cable connectors for producing your own connecting cables. The connectors can be quickly attached to the cable without special tools. Only the outer sheath of the cable is removed. The connectors are available for M8 and M12 screw connectors and meet protection class IP 65.



| Connector           | Weight<br>kg | Order code        |
|---------------------|--------------|-------------------|
| M8 screw connector  | 0,017        | <b>P8SCS0803J</b> |
| M12 screw connector | 0,022        | <b>P8SCS1204J</b> |

### Ready to use connecting cables with connectors at each end

As accessories the system comprises a large number of different cables in order to meet all requirements that may arise and to make the installation simple, fast and reliable.

Cables with moulded 8 mm snap-in round contacts in both ends. The cables are available in two types, one with a straight male and female connectors respectively, and one with a straight 3-pole male connector in one end and an angled 3-pole female connector in the other end.



#### Technical data

##### Contacts

Moulded 8 mm snap-in male/female contacts.  
 Enclosure IP67

##### Cable

Conductor 3x0,25 mm<sup>2</sup> (32x0,10 mm<sup>2</sup>)  
 Sheath PVC/PUR  
 Colour Black

**Installation and Maintenance**



Disconnect air and electrical supplies before attempting repair or maintenance.  
 See ISO 4414-1982 for safety requirements covering the installation and use of pneumatic equipment.

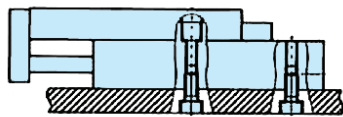
**Selection**

- 1 Do not apply a load over the operating limit range.**  
 Select the model considering max. allowable load and allowable moment. When actuator is used outside of operating limits, eccentric loads on guide will be in excess this causing vibration on guide and inaccuracy and shortens life
- 2 If intermediate stops by external stopper is done, avoid ejection.**  
 If ejection occurs, it may cause damage. In case the slide table is stopped at intermediate positions by an external stopper then forwarded to the front, return the slide table to the back for just a moment to retract the stopper, then supply pressure to the opposite port to operate slide table.
- 3 Do not apply excessive forces and impacts.**  
 This will cause problems and possible failure.

**Mounting**

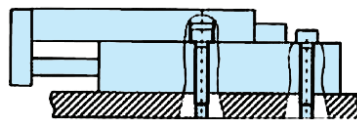
- 1 Do not scratch and dent mounting side of body, table and end plate.**  
 The damage will result in a decrease in parallelism, vibration of guide and an increase in moving part resistance.
- 2 Do not scratch and dent forward side of rail and guide.**  
 This can cause vibration and increases moving part resistance.
- 3 Do not apply excessive power and load when work is mounted.**  
 Vibration on guide and moving part resistance will result when power over the allowable moment is applied.
- 4 Flatness of mounting surface should be less than 0.02mm.**  
 Insufficient flatness of workpiece or base to which the Slide Table is mounted can cause generation of play at guide section or increase sliding resistance.
- 5 Select the proper connection with the load which has external support and/or guide mechanism on the outside and align it properly.**
- 6 Avoid contact with the slide table during operation.**  
 Adjuster options create additional pinch points which can cause injury to the operator when table is moving. Preventative measures, e.g. installation of a cover should be taken to avoid such accidents.
- 7 Keep away from objects which are influenced by magnets.**  
 A magnet is built in the guide block for use with sensors, therefore do not use magnetic disk, magnetic card or magnetic tape, else data will be eliminated.
- 8 When mounting a slide table, use appropriate length of screws and do not exceed the maximum tightening torque.**  
 Tightening the screw beyond the designated value may result in a malfunction. Tightening insufficiently may result in position sliding or falling off of the slide table

**Horizontal mounting (Body tapped)**



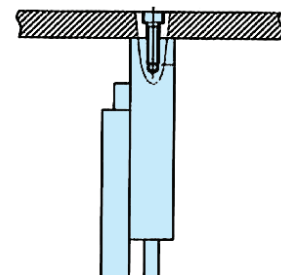
| Order code | Bolt      | Max.torque (Nm) | Max.screw-in depth (L mm) |
|------------|-----------|-----------------|---------------------------|
| P5SS-006   | M4 x 0.7  | 2.1             | 8                         |
| P5SS-008   | M4 x 0.8  | 2.1             | 8                         |
| P5SS-012   | M5 x 0.8  | 4.4             | 10                        |
| P5SS-016   | M6 x 1    | 7.4             | 12                        |
| P5SS-020   | M6 x 1    | 7.4             | 12                        |
| P5SS-025   | M8 x 1.25 | 18              | 16                        |

**Horizontal mounting (Through hole)**



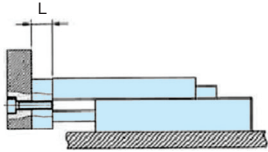
| Order code | Bolt     | Max.torque (Nm) | Max.screw-in depth (L mm) |
|------------|----------|-----------------|---------------------------|
| P5SS-006   | M3 x 0.5 | 1.2             | 11                        |
| P5SS-008   | M3 x 0.5 | 1.2             | 13                        |
| P5SS-012   | M4 x 0.7 | 2.8             | 17                        |
| P5SS-016   | M5 x 0.8 | 5.7             | 24                        |
| P5SS-020   | M5 x 0.8 | 5.7             | 27                        |
| P5SS-025   | M6 x 1   | 10              | 34                        |

**Vertical mounting (Body tapped)**



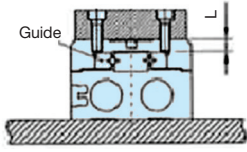
| Order code | Bolt        | Max.torque (Nm) | Max.screw-in depth (L mm) |
|------------|-------------|-----------------|---------------------------|
| P5SS-006   | M2.5 x 0.45 | 0.5             | 3.5                       |
| P5SS-008   | M3 x 0.5    | 0.9             | 4                         |
| P5SS-012   | M4 x 0.7    | 2.1             | 6                         |
| P5SS-016   | M5 x 0.8    | 4.4             | 7                         |
| P5SS-020   | M5 x 0.8    | 4.4             | 8                         |
| P5SS-025   | M6 x 1      | 7.4             | 10                        |

**Tool plate mounting**



| Order code | Bolt      | Max.torque (Nm) | Max.screw-in depth (L mm) |
|------------|-----------|-----------------|---------------------------|
| P5SS-006   | M3 x 0.5  | 0.9             | 5                         |
| P5SS-008   | M4 x 0.8  | 2.1             | 6                         |
| P5SS-012   | M5 x 0.8  | 4.4             | 8                         |
| P5SS-016   | M6 x 1    | 7.4             | 10                        |
| P5SS-020   | M6 x 1    | 7.4             | 13                        |
| P5SS-025   | M8 x 1.25 | 18              | 15                        |

**Top face mounting**



When attaching work piece to guide use a bolt that is at least 0.5mm shorter than the maximum thread depth. Longer bolts can cause malfunction due to contact with the guide bearings.

**1** The positioning hole on the table and the positioning hole at the bottom of the body do not have the same center.

Use these holes during reinstallation after the table has been removed for the maintenance of an identical product.

**Precautions for adjuster option**

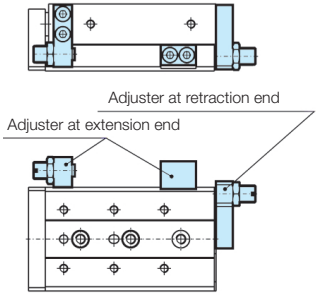
**Stroke adjuster**

- 1** Never replace the original adjuster bolts.  
Impact energy causes play, damage etc.
- 2** Refer to the below table for lock nut tightening torque.  
If the lock nut is not tightened sufficiently, this leads to low positioning accuracy.

| Order code | Tightening torque (Nm) |
|------------|------------------------|
| P5SS-006   | 3                      |
| P5SS-008   | 5                      |
| P5SS-012   | 12.5                   |
| P5SS-016   | 25                     |
| P5SS-020   | 43                     |
| P5SS-025   | 69                     |

- 3** When stroke adjuster is adjusted, do not hit the table with the wrench.  
This can cause excessive play.

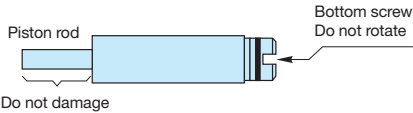
**Stroke Adjuster with adjustable bolt**



Adjustable stroke range: 0-5mm  
**EA:** Adjuster at extension end  
**RA:** Adjuster at retraction end

**With shock absorber**

- 1** Do not rotate the screw set on the bottom of shock absorber.  
This is not the screw for adjusting. If this screw is rotated, it may cause oil leakage.
- 2** Do not scratch the exposed portion of the piston rod.  
Decrease in life or malfunction may result.



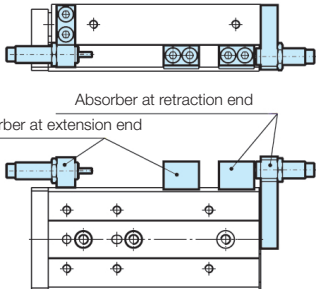
- 3** Shock absorber is considered a consumable component. When energy absorption is decreased replace it.

| Order code | Item number of shock absorber |
|------------|-------------------------------|
| P5SS-006   | Not applicable                |
| P5SS-008   | MC10EUMC                      |
| P5SS-012   | MC10EUMC                      |
| P5SS-016   | MC25EUM-NB                    |
| P5SS-020   | MC150M                        |
| P5SS-025   | MC150M                        |

- 4** Refer to the below table for lock nut tightening torque.  
If the lock nut is not tightened sufficiently, this leads to low positioning accuracy.

| Order code | Tightening torque (Nm) |
|------------|------------------------|
| P5SS-008   | 1.67                   |
| P5SS-012   | 1.67                   |
| P5SS-016   | 3.14                   |
| P5SS-020   | 10.8                   |
| P5SS-025   | 10.8                   |

**Stroke Adjuster with shock absorber**



Enables adjustment of stroke.  
 Absorbs the collision at stroke end and stops smoothly  
**ESK:** Absorber at extension end  
**RSK:** Absorber at retraction end

**Precautions for adjuster (optional item) :**

**Stroke adjuster**

- ❶ **Do not replace the special designed bolt with any other bolts.**

It could loosen or get damaged by the impact force.

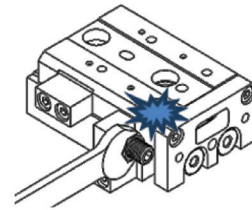
- ❷ **Please tighten the fixing nut according to the tightness torque chart below.**

Failure to tighten the fixing screw will affect the precision.

- ❸ **When adjusting the stroke adjuster, be careful the wrench should not make contact with the slide.**

May cause damage or sway the slide

**Adjuster torque**



| Order code | Tightening torque (Nm) |
|------------|------------------------|
| P5SS-006   | 3                      |
| P5SS-008   | 5                      |
| P5SS-012   | 12.5                   |
| P5SS-016   | 25                     |
| P5SS-020   | 43                     |
| P5SS-025   | 69                     |

| Order code | Adjuster at both ends          |             |                     |             |                                 |             |
|------------|--------------------------------|-------------|---------------------|-------------|---------------------------------|-------------|
|            | Adjuster at extension end (EA) |             |                     |             | Adjuster at retraction end (RA) |             |
|            | Body mounting part             |             | Table mounting part |             | Body mounting part              |             |
|            | Thread size                    | Torque (Nm) | Thread size         | Torque (Nm) | Thread size                     | Torque (Nm) |
| P5SS-006   | M2.5 x 10                      | 0.5         | M2.5 x 10           | 0.5         | M2.5 x 10                       | 0.5         |
| P5SS-008   | M3 x 10                        | 0.9         | M3 x 10             | 0.9         | M3 x 10                         | 0.9         |
| P5SS-012   | M4 x 16                        | 2.1         | M4 x 16             | 2.1         | M4 x 16                         | 2.1         |
| P5SS-016   | M5 x 16                        | 4.5         | M5 x 16             | 4.5         | M5 x 16                         | 4.5         |
| P5SS-020   | M6 x 20                        | 7.5         | M6 x 20             | 7.5         | M6 x 20                         | 4.5         |
| P5SS-025   | M8 x 25                        | 18          | M8 x 25             | 18          | M8 x 25                         | 7.5         |

**Environment**

- ❶ **Do not use in atmosphere where the actuator contacts directly the liquid such as cutting oil.**

Conditions where the cylinder piston rod and guide shafts are exposed directly to cutting oil, coolant and oil mist lead to vibration, increase of moving part resistance, air leakage, etc.

- ❷ **Do not use in atmosphere where the actuator contacts directly the material such as powder dust, dust, spatter etc.**

- ❸ **Do not use in direct sun light.**

- ❹ **Do not use in environment where there is heat source.**

Use a cover when there is a heat source around the actuator, or if temperature of product increases and exceeds operating temperature range by emissive heat.

- ❺ **Do not subject it to excessive vibration and/or impact.**

This results in damage and/or malfunction.

# Specifying air quality (purity) in accordance with ISO8573-1:2010, the international standard for Compressed Air Quality

ISO8573-1 is the primary document used from the ISO8573 series as it is this document which specifies the amount of contamination allowed in each cubic metre of compressed air.

ISO8573-1 lists the main contaminants as Solid Particulate, Water and Oil. The purity levels for each contaminant are shown separately in tabular form, however for ease of use, this document combines all three contaminants into one easy to use table.

| ISO8573-1:2010 CLASS | Solid Particulate  |                |              |                                      | Water                    |                         | Oil   |
|----------------------|--|----------------|--------------|--------------------------------------|--------------------------|-------------------------|---|
|                      | Maximum number of particles per m <sup>3</sup>                                 |                |              | Mass Concentration mg/m <sup>3</sup> | Vapour Pressure Dewpoint | Liquid g/m <sup>3</sup> | Total Oil (aerosol liquid and vapour) mg/m <sup>3</sup> |
|                      | 0,1 - 0,5 micron   | 0,5 - 1 micron | 1 - 5 micron |                                      |                          |                         |   |
| 0                    | As specified by the equipment user or supplier and more stringent than Class 1 |                |              |                                      |                          |                         |   |
| 1                    | ≤ 20 000   | ≤ 400          | ≤ 10         | -                                    | ≤ -70 °C                 | -                       | 0,01  |
| 2                    | ≤ 400 000  | ≤ 6 000        | ≤ 100        | -                                    | ≤ -40 °C                 | -                       | 0,1   |
| 3                    | -  | ≤ 90 000       | ≤ 1 000      | -                                    | ≤ -20 °C                 | -                       | 1   |
| 4                    | -  | -              | ≤ 10 000     | -                                    | ≤ +3 °C                  | -                       | 5   |
| 5                    | -  | -              | ≤ 100 000    | -                                    | ≤ +7 °C                  | -                       | -   |
| 6                    | -  | -              | -            | ≤ 5                                  | ≤ +10 °C                 | -                       | -   |
| 7                    | -  | -              | -            | 5 - 10                               | -                        | ≤ 0,5                   | -   |
| 8                    | -  | -              | -            | -                                    | -                        | 0,5 - 5                 | -   |
| 9                    | -  | -              | -            | -                                    | -                        | 5 - 10                  | -   |
| X                    | -  | -              | -            | > 10                                 | -                        | > 10                    | > 10  |

## Specifying air purity in accordance with ISO8573-1:2010

When specifying the purity of air required, the standard must always be referenced, followed by the purity class selected for each contaminant (a different purity class can be selected for each contamination if required).

An example of how to write an air quality specification is shown below:

### ISO 8573-1:2010 Class 1.2.1

ISO 8573-1:2010 refers to the standard document and its revision, the three digits refer to the purity classifications selected for solid particulate, water and total oil. Selecting an air purity class of 1.2.1 would specify the following air quality when operating at the standard's reference conditions :

#### Class 1 - Particulate

In each cubic metre of compressed air, the particulate count should not exceed 20,000 particles in the 0.1 - 0.5 micron size range, 400 particles in the 0.5 - 1 micron size range and 10 particles in the 1 - 5 micron size range.

#### Class 2 - Water

A pressure dewpoint (PDP) of -40°C or better is required and no liquid water is allowed.

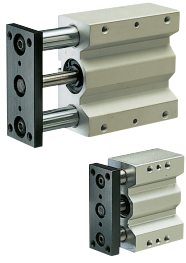
#### Class 1 - Oil

In each cubic metre of compressed air, not more than 0.01mg of oil is allowed. This is a total level for liquid oil, oil aerosol and oil vapour.

## ISO8573-1:2010 Class zero

- **Class 0 does not mean zero contamination.**
- **Class 0 requires the user and the equipment manufacturer to agree contamination levels as part of a written specification.**
- **The agreed contamination levels for a Class 0 specification should be within the measurement capabilities of the test equipment and test methods shown in ISO8573 Pt 2 to Pt 9.**
- **The agreed Class 0 specification must be written on all documentation to be in accordance with the standard.**
- **Stating Class 0 without the agreed specification is meaningless and not in accordance with the standard.**
- **A number of compressor manufacturers claim that the delivered air from their oil-free compressors is in compliance with Class 0.**
- **If the compressor was tested in clean room conditions, the contamination detected at the outlet will be minimal. Should the same compressor now be installed in typical urban environment, the level of contamination will be dependent upon what is drawn into the compressor intake, rendering the Class 0 claim invalid.**
- **A compressor delivering air to Class 0 will still require purification equipment in both the compressor room and at the point of use for the Class 0 purity to be maintained at the application.**
- **Air for critical applications such as breathing, medical, food, etc typically only requires air quality to Class 2.2.1 or Class 2.1.1.**
- **Purification of air to meet a Class 0 specification is only cost effective if carried out at the point of use.**

### Compact Cylinders - P5T



- Complete cylinder function with integral guidance
- Stainless steel guide rods
- Wide range of standard strokes, diameter 16-100 mm
- Flexible porting as standard
- End stop cushions as standard

### Stopper Cylinders - STV / STVR



- Available with hydraulic Industrial shock absorbers
- Vertical and horizontal versions
- Integrated shock absorber for heavy conveyed loads
- Roller for lower conveyed load weights
- Direct stopping piston rod for heavy conveyed loads

### Twin Rod Cylinders - RDV / AZV

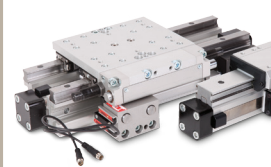


**RDV Series**

**AZ Series**

- Non rotating
- Double acting
- Adjustable cushioning
- Magnetic piston as standard

### Rodless Cylinders - OSP-P



- Compact: guide rail integrated in the cylinder profile
- Long lifetime and high service intervals
- High loads and moments
- Easy to re-adjust through simple design => easy to maintain
- Integrated scraper system and grease nipples

### Rodless Cylinders - OSP-L



- Completely modular design
- Compatible with the comprehensive ORIGA OSP system component range
- High loads and moments
- Space saving
- For a wide range of loads, speeds and motion profiles

### Rodless Magnetic Cylinders - P1Z



- Double acting with guide
- Magnetically coupled without mechanical connection
- Mechanical protection in case of occasional overload due to magnetic uncoupling
- Piston chamber and Slide are pressure tight
- Pressure tight and leak free system

### Shock Absorbers - SA



- Integral stop collar
- Soft pad
- Rectangular flange
- Foot mounting
- Adjustable without return spring
- For use with external air-oil tank

### Shock Absorbers - MC-SC



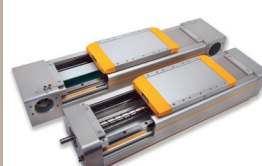
- Compact and heavy duty versions
- High energy absorption
- Low return force
- Long service life
- Increases productivity
- Reduces maintenance

### Electric Linear Actuators - OSP-E



- For particularly high requirements regarding loads and forces
- For high-speed applications and highly dynamic motion profiles
- BHD with toothed belt and integrated heavy duty guide: roller guide or re-circulating ball bearing guide

### Electric Linear Actuators - HMR



- Three alternative drive technologies in one profile
- Unique flexibility and reliability
- High speed and precision
- Two profile versions, four profile sizes
- Optional IP54 snap-in covers

PDE2669TCUK

## Handling Products

---

# Parker Worldwide

## Europe, Middle East, Africa

**AE – United Arab Emirates,** Dubai  
Tel: +971 4 8127100  
parker.me@parker.com

**AT – Austria,** Wiener Neustadt  
Tel: +43 (0)2622 23501-0  
parker.austria@parker.com

**AT – Eastern Europe,** Wiener Neustadt  
Tel: +43 (0)2622 23501 900  
parker.easteurope@parker.com

**AZ – Azerbaijan,** Baku  
Tel: +994 50 2233 458  
parker.azerbaijan@parker.com

**BE/LU – Belgium,** Nivelles  
Tel: +32 (0)67 280 900  
parker.belgium@parker.com

**BY – Belarus,** Minsk  
Tel: +375 17 209 9399  
parker.belarus@parker.com

**CH – Switzerland,** Etoy  
Tel: +41 (0)21 821 87 00  
parker.switzerland@parker.com

**CZ – Czech Republic,** Klecany  
Tel: +420 284 083 111  
parker.czechrepublic@parker.com

**DE – Germany,** Kaarst  
Tel: +49 (0)2131 4016 0  
parker.germany@parker.com

**DK – Denmark,** Ballerup  
Tel: +45 43 56 04 00  
parker.denmark@parker.com

**ES – Spain,** Madrid  
Tel: +34 902 330 001  
parker.spain@parker.com

**FI – Finland,** Vantaa  
Tel: +358 (0)20 753 2500  
parker.finland@parker.com

**FR – France,** Contamine s/Arve  
Tel: +33 (0)4 50 25 80 25  
parker.france@parker.com

**GR – Greece,** Athens  
Tel: +30 210 933 6450  
parker.greece@parker.com

**HU – Hungary,** Budapest  
Tel: +36 1 220 4155  
parker.hungary@parker.com

**IE – Ireland,** Dublin  
Tel: +353 (0)1 466 6370  
parker.ireland@parker.com

**IT – Italy,** Corsico (MI)  
Tel: +39 02 45 19 21  
parker.italy@parker.com

**KZ – Kazakhstan,** Almaty  
Tel: +7 7272 505 800  
parker.easteurope@parker.com

**NL – The Netherlands,** Oldenzaal  
Tel: +31 (0)541 585 000  
parker.nl@parker.com

**NO – Norway,** Asker  
Tel: +47 66 75 34 00  
parker.norway@parker.com

**PL – Poland,** Warsaw  
Tel: +48 (0)22 573 24 00  
parker.poland@parker.com

**PT – Portugal,** Leca da Palmeira  
Tel: +351 22 999 7360  
parker.portugal@parker.com

**RO – Romania,** Bucharest  
Tel: +40 21 252 1382  
parker.romania@parker.com

**RU – Russia,** Moscow  
Tel: +7 495 645-2156  
parker.russia@parker.com

**SE – Sweden,** Spånga  
Tel: +46 (0)8 59 79 50 00  
parker.sweden@parker.com

**SK – Slovakia,** Banská Bystrica  
Tel: +421 484 162 252  
parker.slovakia@parker.com

**SL – Slovenia,** Novo Mesto  
Tel: +386 7 337 6650  
parker.slovenia@parker.com

**TR – Turkey,** Istanbul  
Tel: +90 216 4997081  
parker.turkey@parker.com

**UA – Ukraine,** Kiev  
Tel: +380 44 494 2731  
parker.ukraine@parker.com

**UK – United Kingdom,** Warwick  
Tel: +44 (0)1926 317 878  
parker.uk@parker.com

**ZA – South Africa,** Kempton Park  
Tel: +27 (0)11 961 0700  
parker.southafrica@parker.com

## North America

**CA – Canada,** Milton, Ontario  
Tel: +1 905 693 3000

**US – USA,** Cleveland  
Tel: +1 216 896 3000

## Asia Pacific

**AU – Australia,** Castle Hill  
Tel: +61 (0)2-9634 7777

**CN – China,** Shanghai  
Tel: +86 21 2899 5000

**HK – Hong Kong**  
Tel: +852 2428 8008

**IN – India,** Mumbai  
Tel: +91 22 6513 7081-85

**JP – Japan,** Tokyo  
Tel: +81 (0)3 6408 3901

**KR – South Korea,** Seoul  
Tel: +82 2 559 0400

**MY – Malaysia,** Shah Alam  
Tel: +60 3 7849 0800

**NZ – New Zealand,** Mt Wellington  
Tel: +64 9 574 1744

**SG – Singapore**  
Tel: +65 6887 6300

**TH – Thailand,** Bangkok  
Tel: +662 186 7000-99

**TW – Taiwan,** Taipei  
Tel: +886 2 2298 8987

## South America

**AR – Argentina,** Buenos Aires  
Tel: +54 3327 44 4129

**BR – Brazil,** Sao Jose dos Campos  
Tel: +55 800 727 5374

**CL – Chile,** Santiago  
Tel: +56 2 623 1216

**MX – Mexico,** Apodaca  
Tel: +52 81 8156 6000

European Product Information Centre  
Free phone: 00 800 27 27 5374  
(from AT, BE, CH, CZ, DE, DK, EE, ES, FI, FR, IE, IL, IS, IT, LU, MT, NL, NO, PL, PT, RU, SE, SK, UK, ZA)



## Parker Hannifin Ltd.

Tachbrook Park Drive  
Tachbrook Park,  
Warwick, CV34 6TU  
United Kingdom  
Tel.: +44 (0) 1926 317 878  
Fax: +44 (0) 1926 317 855  
parker.uk@parker.com  
www.parker.com